



DIAPHRAGM PUMPS

TECHNICAL CATALOGUE - REV. 00/2016



Capitanio Airpumps s.r.l. – Via Brigata Mazzini 35/A 36016 – Thiene (VI)
Tel. +39 0445 185.65.65 – Fax. +39 0445 185.65.00
www.airpumps.it capitanio@airpumps.it

INDEX

Capitania Airpumps	4
DN8 Aluminum (3/8").....	5
DN8 Stainless Steel (3/8")	7
DN8 Polypropylene (3/8").....	9
DN12 Aluminum (1/2").....	11
DN15 Aluminum (1/2").....	13
DN15 Stainless Steel (1/2")	15
DN15 Polypropylene (1/2")	17
DN15 PVDF (1/2")	19
DN15 PTFE (1/2").....	21
DN20 Aluminum (3/4").....	23
DN20 Polypropylene.....	25
DN20 Polyethylene(3/4").....	27
DN25 Aluminum (1")	29
DN25 Polypropylene (1").....	31
DN25 PTFE (1")	33
DN28 Polypropylene (1").....	35
DN28 PVDF (1")	37
DN40 Aluminum (1" 1/2").....	39
DN50 Polypropylene (2").....	41
DN50 PVDF (2")	43
DN50 Stainless Steel (1/2")	45
Reverse.....	47
Customization.....	48
Accessories	50
Pulsation Dampeners	52
Static Pulsation Dampeners.....	53
Inlet Filters	55
Tanks 56	
Sets 57	
Adjusting Kits.....	58
Supports	59
Fast Color.....	60
Lifter 61	

CAPITANIO AIRPUMPS



WHO WE ARE

Since 1979 Capitanio Airpumps designs and produces **double diaphragm** and **piston** air operated pumps, **valves** and **pulsation dampeners**. Suitable for every kind of fluid, adjustable flow and pressure, reversable. Every product is very High Quality and MADE IN ITALY.

REAL ADDED VALUE

Capitanio Airpumps is a dynamic company, fast and punctual in both administration and production. Thanks to this philosophy the company is able to work on **customized projects and products**, offer **prompt technical assistance** and have **spare parts** always ready to be shipped **in stock**.

PATENTS

Capitanio Airpumps owns a few patented products, like the innovative **Reverse** system, the **double diaphragm process Valve** and the **active double diaphragm Pulsation Dampener**. Other products are patent pending.



DN8 ALUMINUM (3/8")



PLUS

- Stainless Steel Screws
- Replaceable Inlet/Outlet valves
- Compact Design



TECHNICAL DATA

Adjustable Flow Rate	0÷16 l/min
Inlet/Outlet Ports	3/8" Gas Thread
Solids Max Size	1 mm
Max suction lift dry / wet	3,5 m / 5 m
Air Inlet	1/4" Gas
Air Supply Pressure (Min / Max)	1 / 6.8 bar
Weight	3,5 Kg
Noise Level	<50 dB [A]
Diaphragms, gaskets, valves	Configurable based on the fluid to process

PERFORMANCE

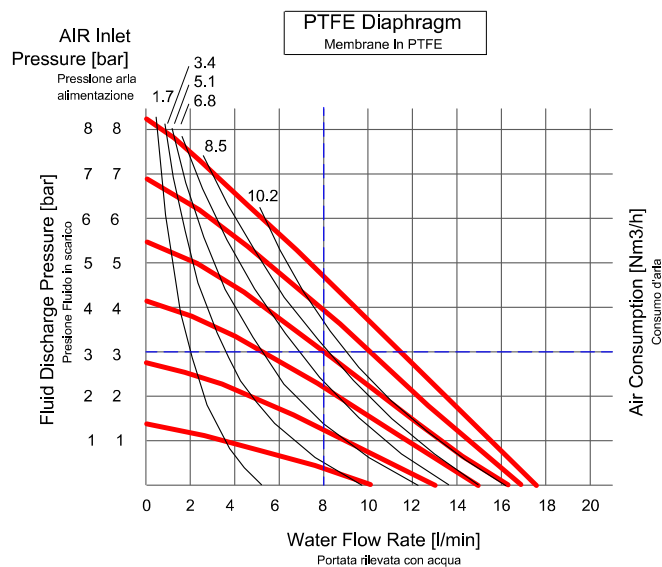

Per pompare 8 l/min ad una pressione di 3 bar, si richiedono di 5.5 bar di alimentazione con consumo d'aria di 8.5 Nm³/h.
To pump 8 lpm against a discharge pressure head of 3 bar, requires 5.5 bar and 8.5 Nm³/h air consumption.

DIMENSIONS

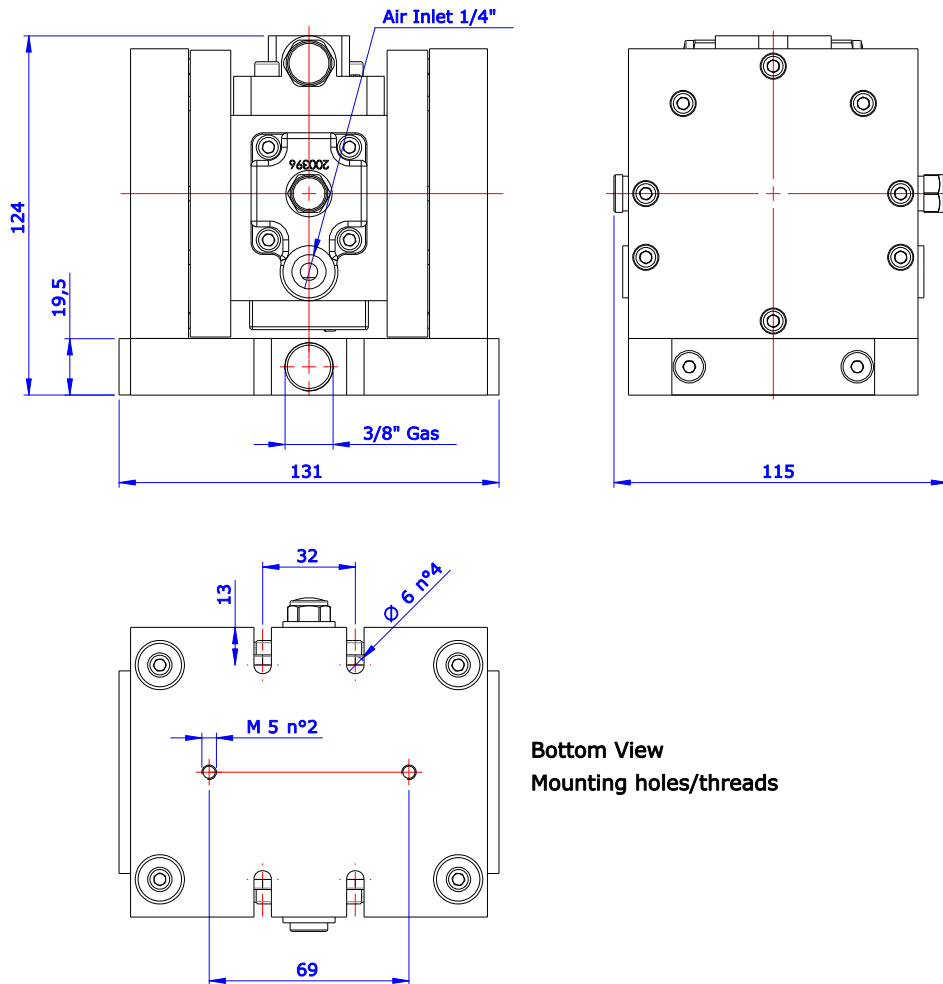

Bottom View
Mounting holes/threads

DN8 STAINLESS STEEL (3/8")



PLUS

- Stainless Steel Screws
- Replaceable Inlet/Outlet valves
- Compact Design



TECHINCAL DATA

Adjustable Flow Rate	0÷16 l/min
Inlet/Outlet Ports	3/8" Gas Thread
Solids Max Size	1 mm
Max suction lift dry / wet	3,5 m / 5 m
Air Inlet	1/4" Gas
Air Supply Pressure (Min / Max)	1 / 6.8 bar
Weight	5,5 Kg
Noise Level	<50 dB [A]
Diaphragms, gaskets, valves	Configurable based on the fluid to process

PERFORMANCE

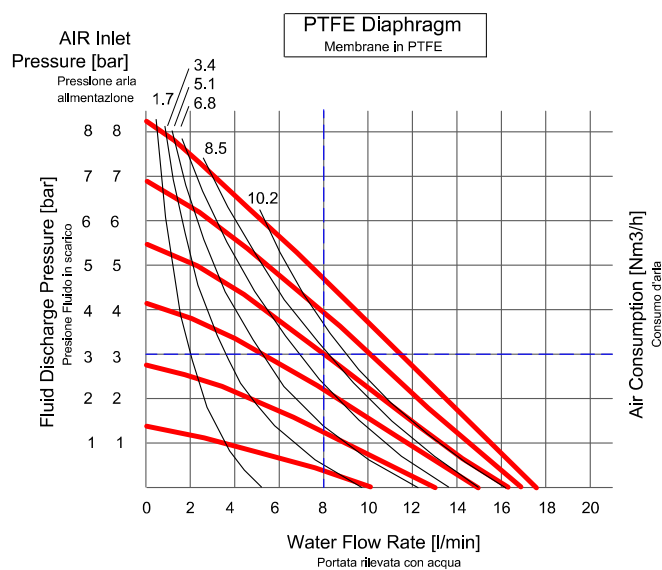

Per pompare 8 l/min ad una pressione di 3 bar, si richiedono di 5.5 bar di alimentazione con consumo d'aria di 8.5 Nm³/h.
To pump 8 lpm against a discharge pressure head of 3 bar, requires 5.5 bar and 8.5 Nm³/h air consumption.

DIMENSIONS

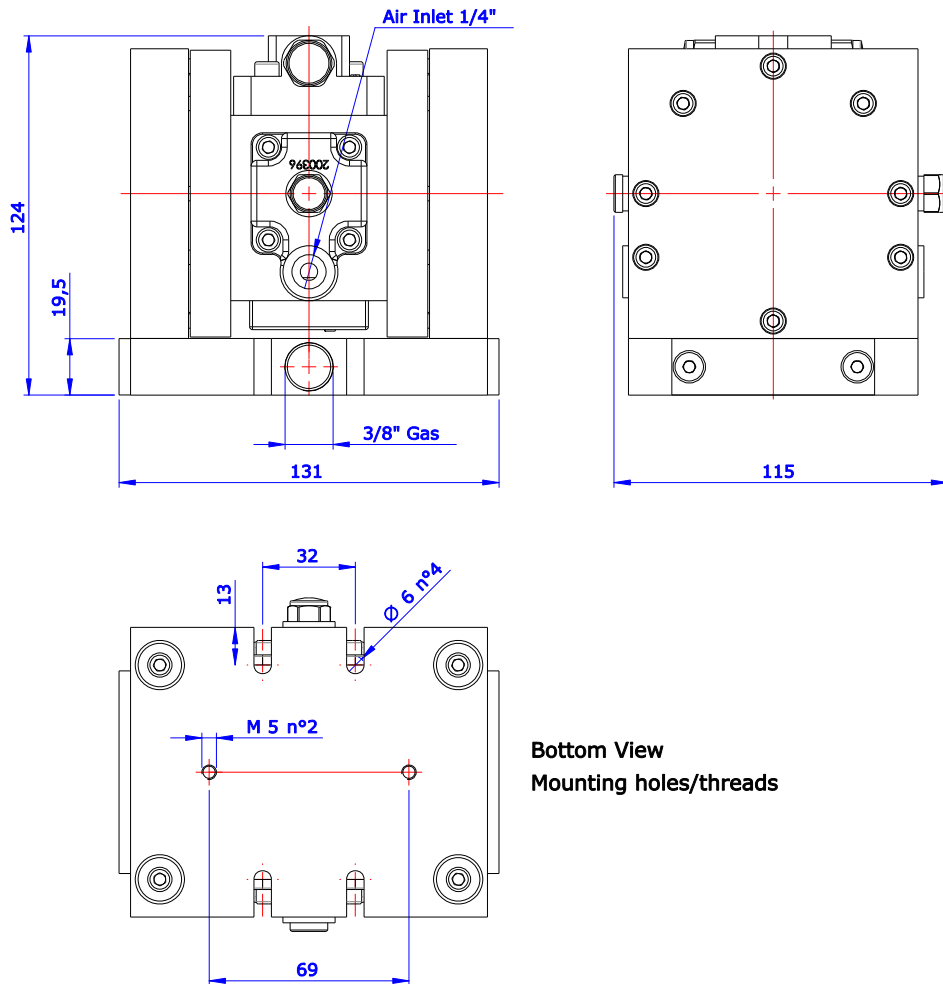

DN8 POLYPROPYLENE (3/8")



PLUS

- Stainless Steel Screws
- Replaceable Inlet/Outlet valves
- Compact Design



TECHNICAL DATA

Adjustable Flow Rate	0÷16 l/min
Inlet/Outlet Ports	3/8" Gas Thread
Solids Max Size	1 mm
Max suction lift dry / wet	3,5 m / 5 m
Air Inlet	1/4" Gas
Air Supply Pressure (Min / Max)	1 / 6.8 bar
Weight	3,5 Kg
Noise Level	<50 dB [A]
Diaphragms, gaskets, valves	Configurable based on the fluid to process

PERFORMANCE

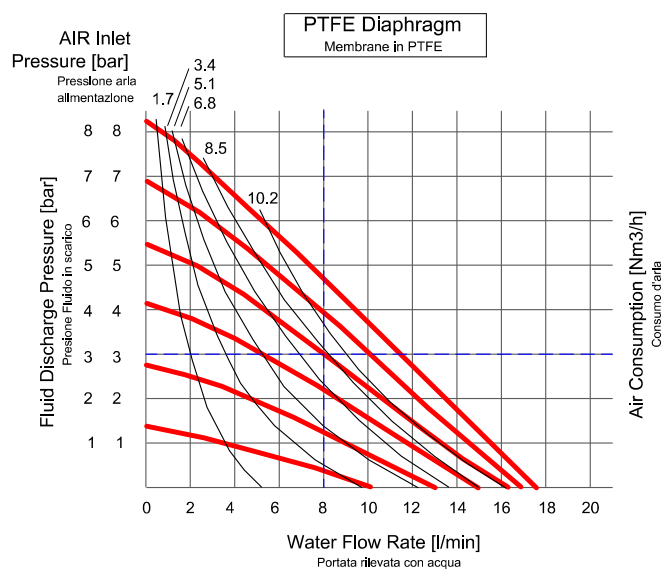

Per pompare 8 l/min ad una pressione di 3 bar, si richiedono di 5.5 bar di alimentazione con consumo d'aria di 8.5 Nm³/h.
To pump 8 lpm against a discharge pressure head of 3 bar, requires 5.5 bar and 8.5 Nm³/h air consumption.

DIMENSIONS

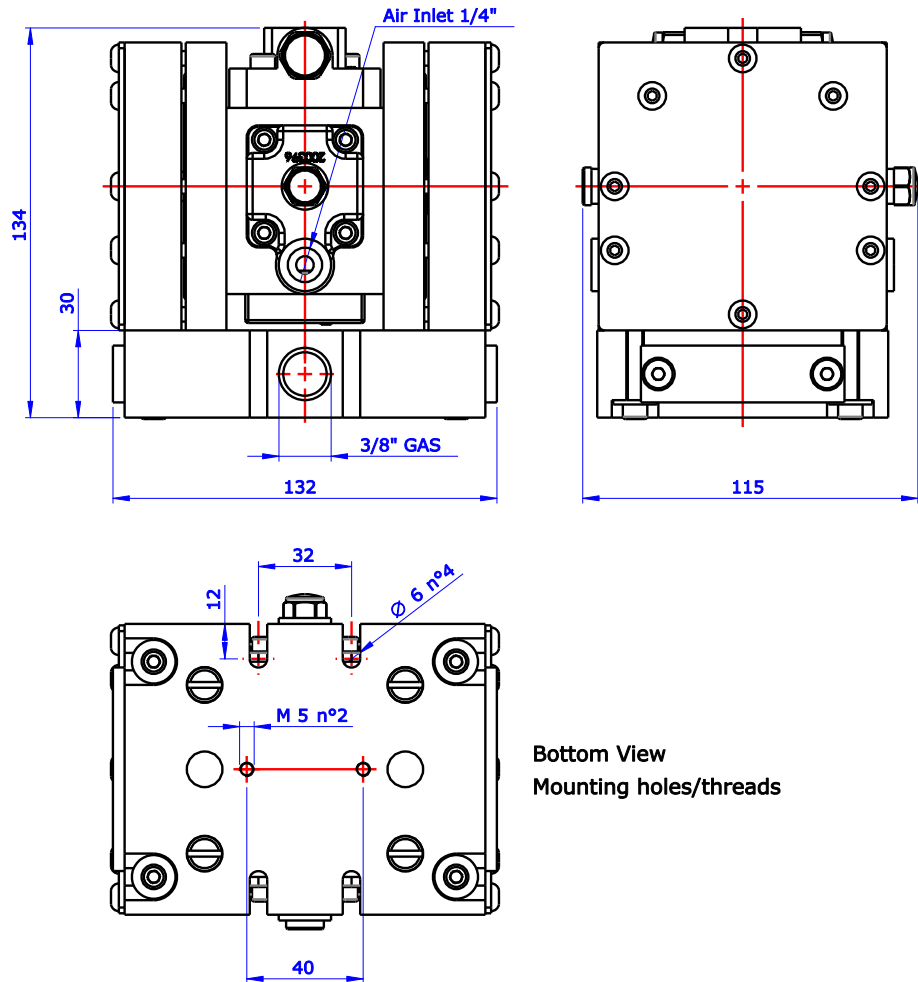

Bottom View
Mounting holes/threads

DN12 ALUMINUM (1/2")



PLUS

- Stainless Steel Screws
- Replaceable Inlet/Outlet valves
- Four Inlet and Four Outlet Ports for easier installations
- Air Treatment unit included



Adjustable Flow Rate

Inlet/Outlet Ports

Solids Max Size

Max suction lift dry / wet

Air Inlet

Air Supply Pressure (Min / Max)

Weight

Noise Level

Diaphragms, gaskets, valves

0÷28 l/min

1/2" Gas Thread (4+4 Ports)

3 mm

4 / 7 m

1/4" Gas

1 / 6.8 bar

5,6 Kg

<50 dB [A]

Configurable based on the fluid to process

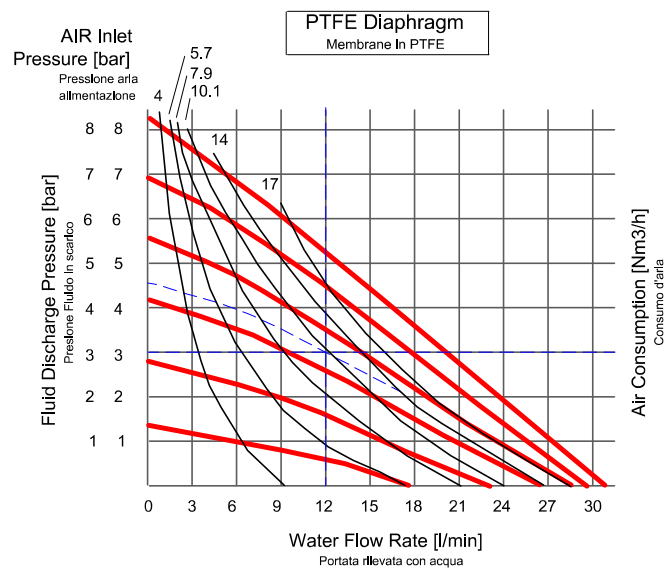

Per pompare 12 l/min ad una pressione di 3 bar, si richiedono di 4.6 bar di alimentazione con consumo d'aria di 14 Nm3/h.
To pump 12 l/min against a discharge pressure head of 3 bar, requires 4.6 bar and 14 Nm3/h air consumption.

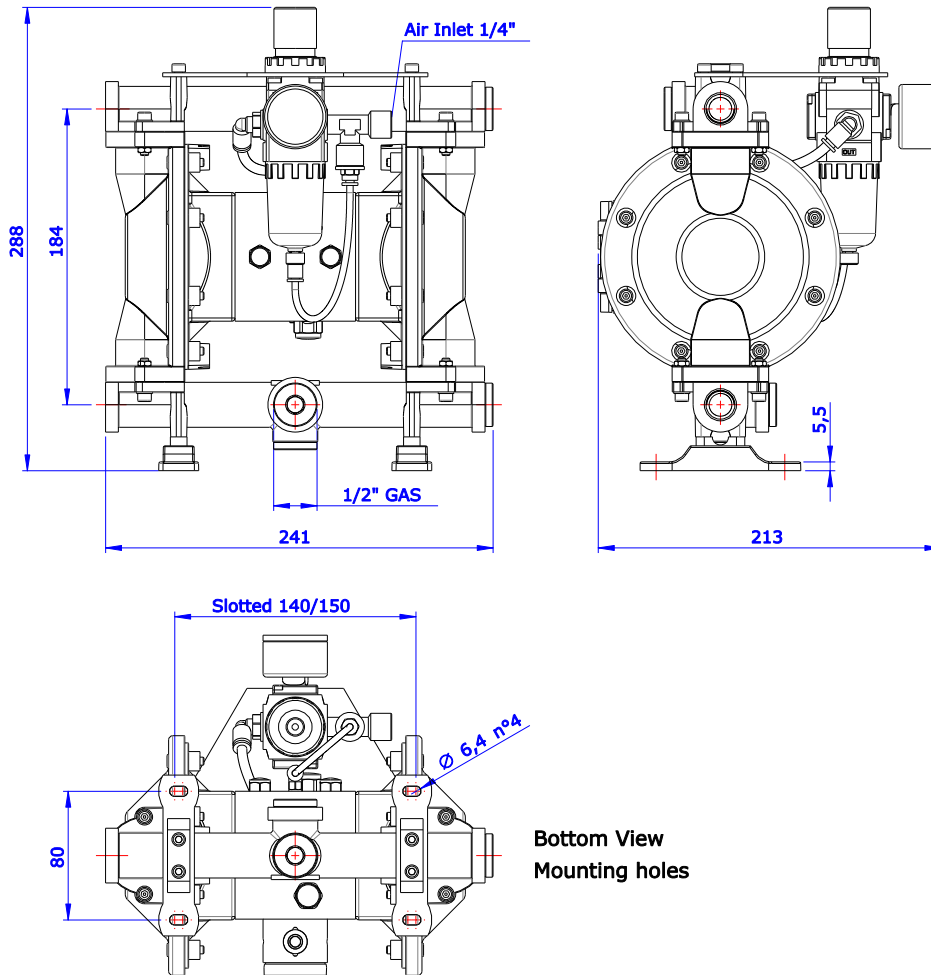

DN15 ALUMINUM (1/2")

PLUS

- Stainless Steel Screws
- Replaceable Inlet/Outlet valves
- Four Inlet and Four Outlet Ports for easier installations



TECHNICAL DATA

Adjustable Flow Rate	0÷52 l/min
Inlet/Outlet Ports	1/2" Gas Thread (4+4 Ports)
Solids Max Size	3 mm
Max suction lift dry / wet	4,5 / 7 m
Air Inlet	1/4" Gas
Air Supply Pressure (Min / Max)	1 / 6.8 bar
Weight	4,5 Kg
Noise Level	<50 dB [A]
Diaphragms, gaskets, valves	Configurable based on the fluid to process

PERFORMANCE

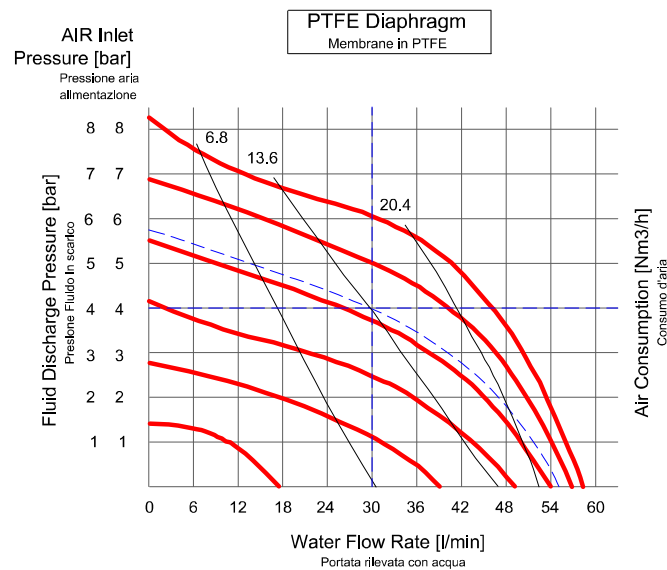

Per pompare 30 l/min ad una pressione di 4 bar, si richiedono di 5.7 bar di alimentazione con consumo d'aria di 13 Nm3/h.
To pump 30 lpm against a discharge pressure head of 4 bar, requires 5.7 bar and 13 Nm3/h air consumption.

DIMENSIONS

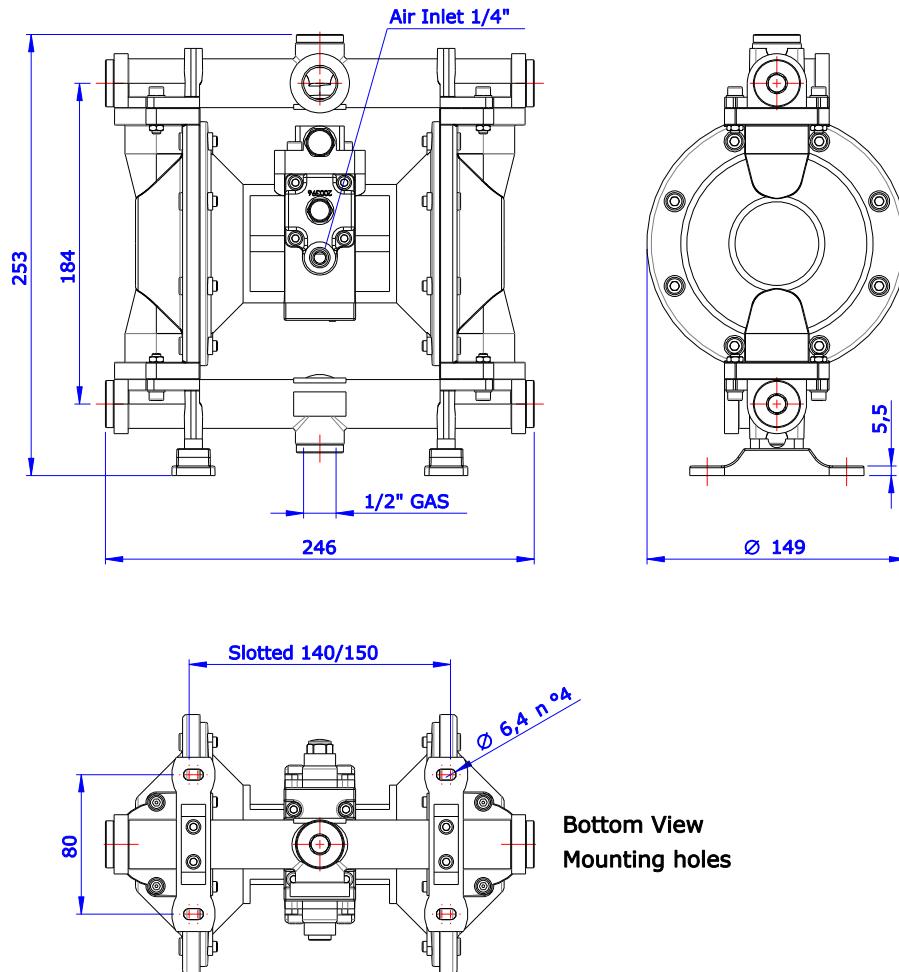

DN15 STAINLESS STEEL (1/2")



PLUS

- Wet parts in Stainless Steel AISI304 or AISI316L
- Replaceable Inlet/Outlet valves
- Three Inlet and Four Outlet Ports for easier installations



TECHNICAL DATA

Adjustable Flow Rate	0÷38 l/min
Inlet/Outlet Ports	1/2" Gas Thread (4+4 Ports)
Solids Max Size	2 mm
Max suction lift dry / wet	4,5 / 7 m
Air Inlet	1/4" Gas
Air Supply Pressure (Min / Max)	1 / 6.8 bar
Weight	13 Kg
Noise Level	<50 dB [A]
Diaphragms, gaskets, valves	Configurable based on the fluid to process

PERFORMANCE

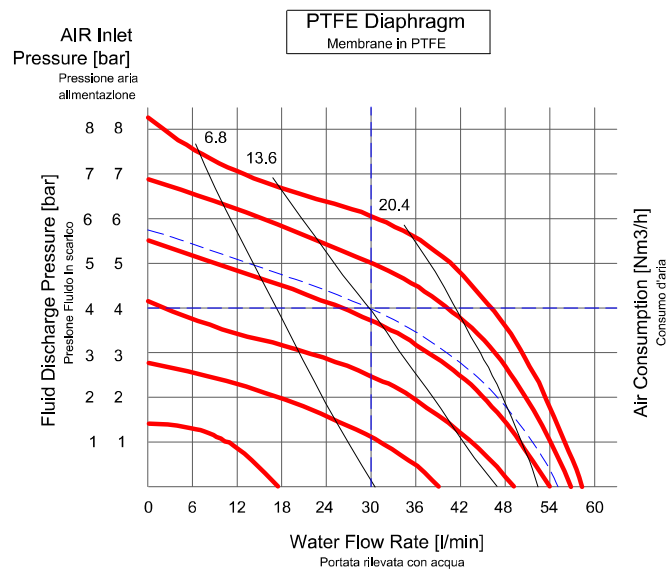

Per pompare 30 l/min ad una pressione di 4 bar, si richiedono di 5.7 bar di alimentazione con consumo d'aria di 13 Nm3/h.
To pump 30 lpm against a discharge pressure head of 4 bar, requires 5.7 bar and 13 Nm3/h air consumption.

DIMENSIONS

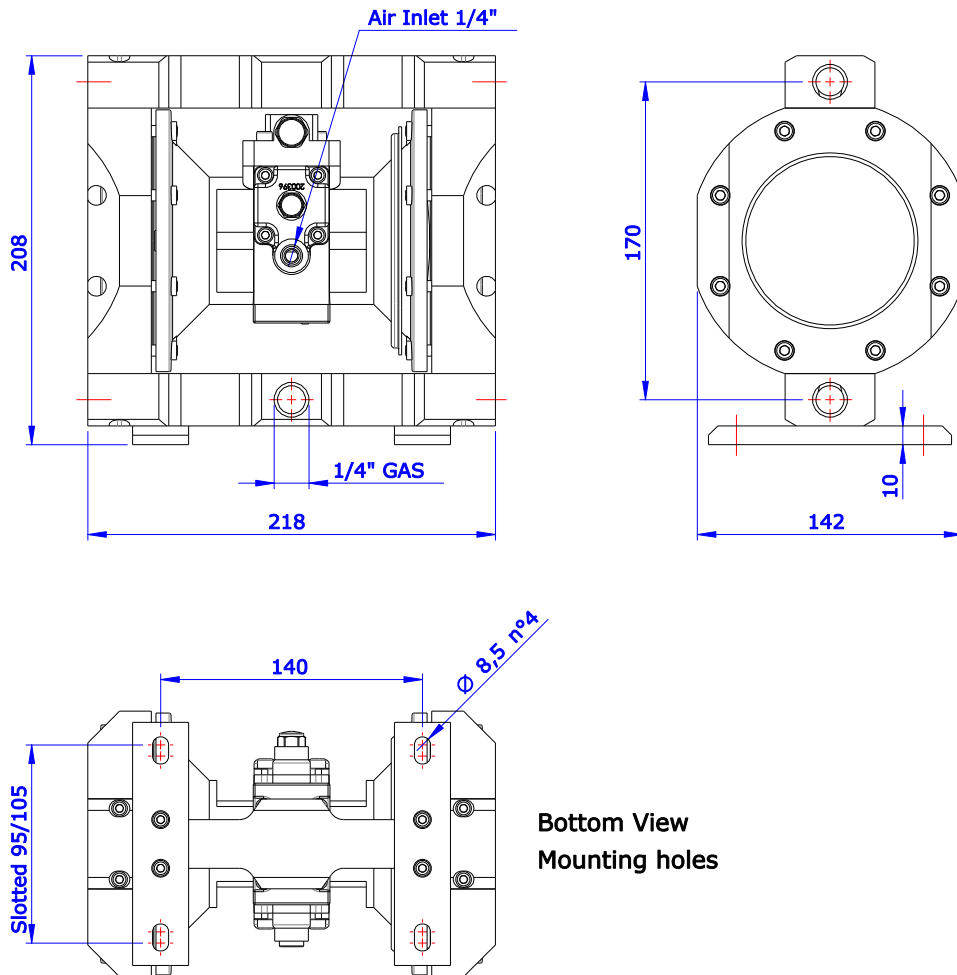

DN15 POLYPROPYLENE (1/2")



PLUS

- Stainless Steel Screws
- Replaceable Inlet/Outlet valves
- 180° Rotatable Inlet/Outlet Ports



TECHNICAL DATA

Adjustable Flow Rate	0÷52 l/min
Inlet/Outlet Ports	1/2" Gas Thread
Solids Max Size	3 mm
Max suction lift dry / wet	4,5 / 7 m
Air Inlet	1/4" Gas
Air Supply Pressure (Min / Max)	1 / 6.8 bar
Weight	5 Kg
Noise Level	<50 dB [A]
Diaphragms, gaskets, valves	Configurable based on the fluid to process

PERFORMANCE

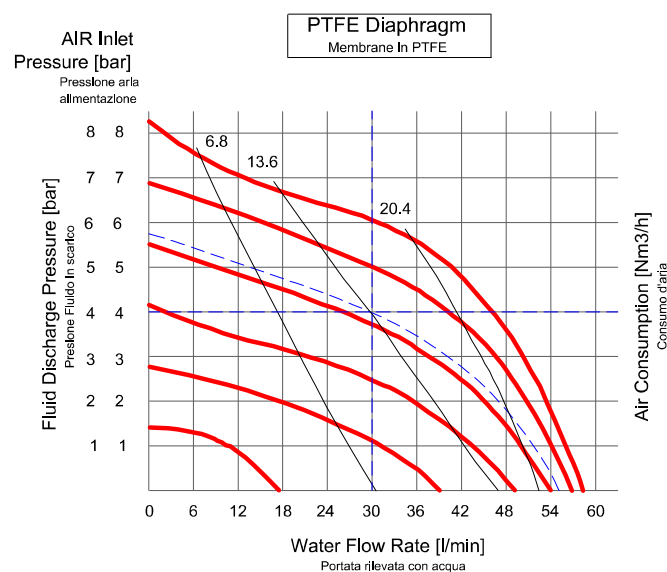

Per pompare 30 litri ad una pressione di 4 bar, si richiedono di 5.7 bar di alimentazione con consumo d'aria di 13 Nm3/h.
To pump 30 lpm against a discharge pressure head of 4 bar, requires 5.7 bar and 13 Nm3/h air consumption.

DIMENSIONS

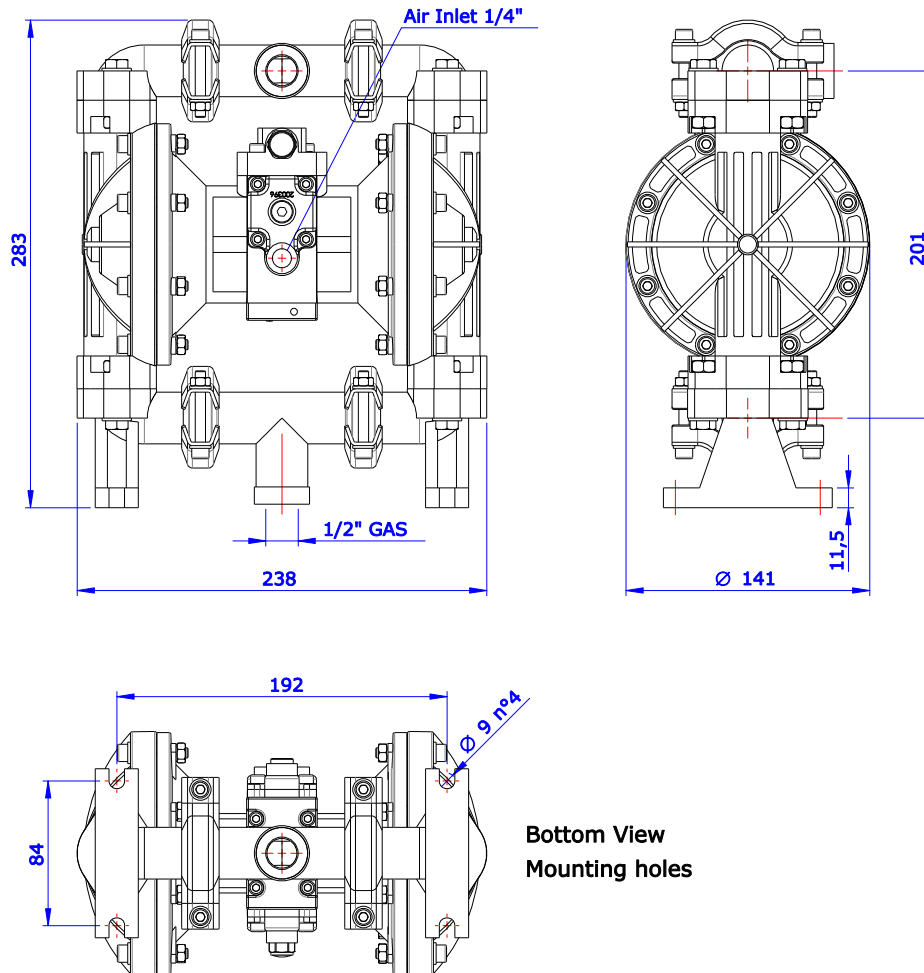

DN15 PVDF (1/2")



PLUS

- Stainless Steel Screws
- Replaceable Inlet/Outlet valves
- 180° Rotatable Inlet/Outlet Ports



TECHINCAL DATA

Adjustable Flow Rate	0÷52 l/min
Inlet/Outlet Ports	1/2" Gas Thread
Solids Max Size	3 mm
Max suction lift dry / wet	4,5 / 7 m
Air Inlet	1/4" Gas
Air Supply Pressure (Min / Max)	1 / 6.8 bar
Weight	5,5 Kg
Noise Level	<50 dB [A]
Diaphragms, gaskets, valves	Configurable based on the fluid to process

PERFORMANCE

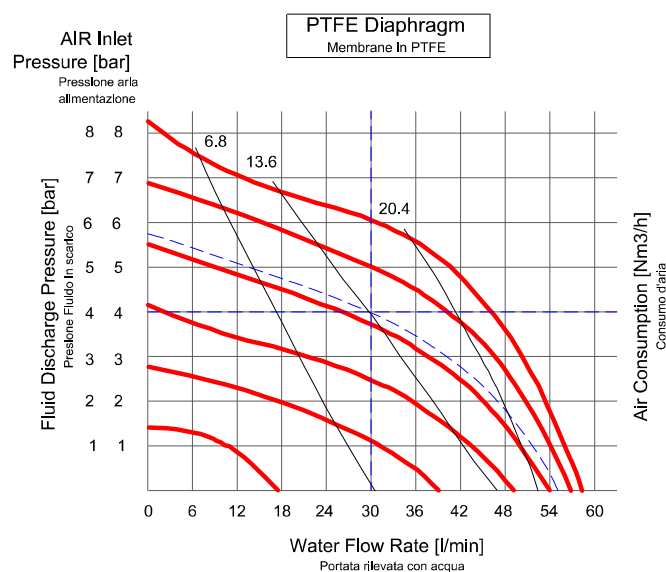

Per pompare 30 litri ad una pressione di 4 bar, si richiedono di 5,7 bar di alimentazione con consumo d'aria di 13 Nm3/h.
To pump 30 lpm against a discharge pressure head of 4 bar, requires 5.7 bar and 13 Nm3/h air consumption.

DIMENSIONS

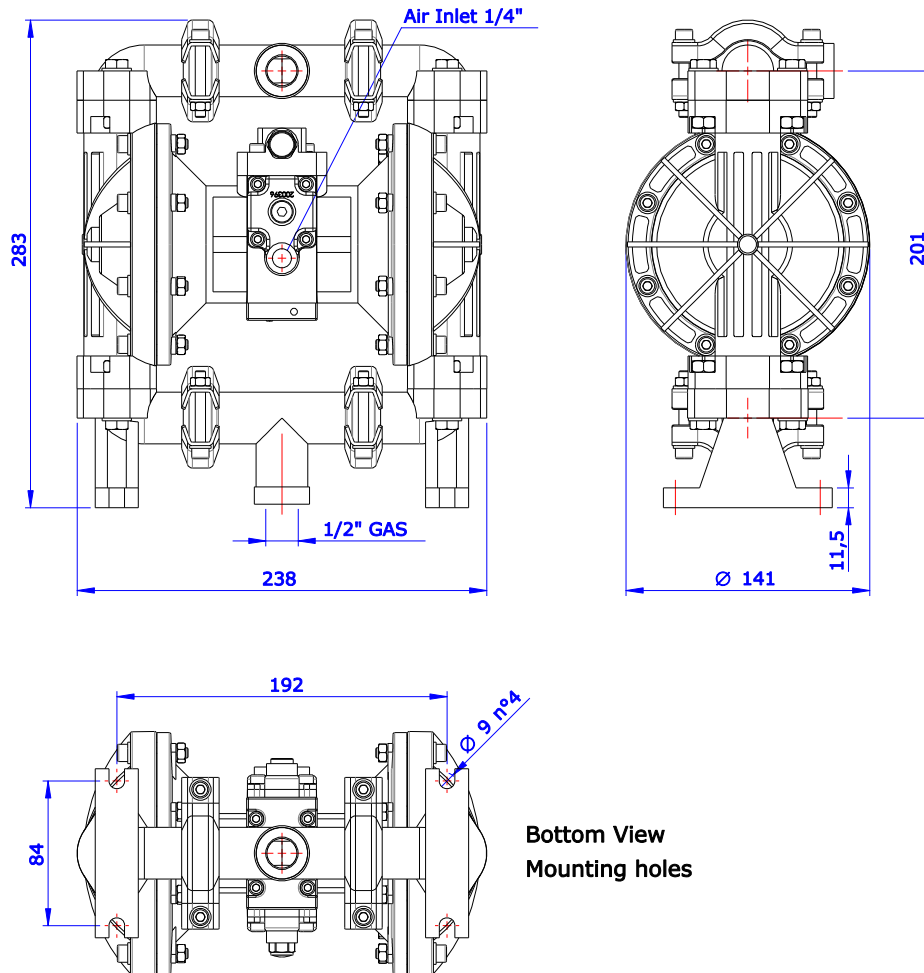

DN15 PTFE (1/2")

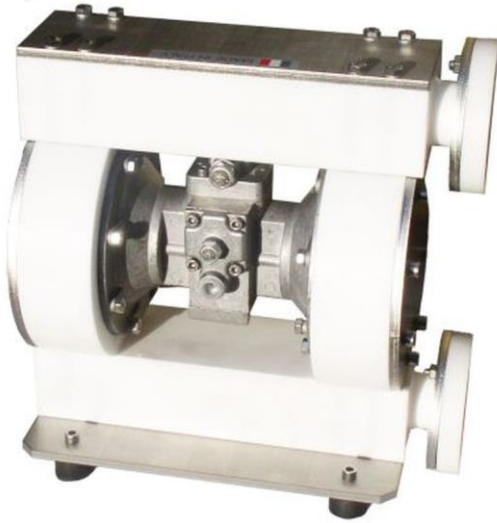

PLUS

- Fluid Side entirely in PTFE
- Stainless Steel Screws



TECHNICAL DATA

Adjustable Flow Rate	0÷52 l/min
Inlet/Outlet Ports	1/2" DIN Flange
Solids Max Size	3 mm
Max suction lift dry / wet	4,5 / 7 m
Air Inlet	1/4" Gas
Air Supply Pressure (Min / Max)	1 / 6.8 bar
Weight	17 Kg
Noise Level	<50 dB [A]
Diaphragms, gaskets, valves	PTFE

PERFORMANCE

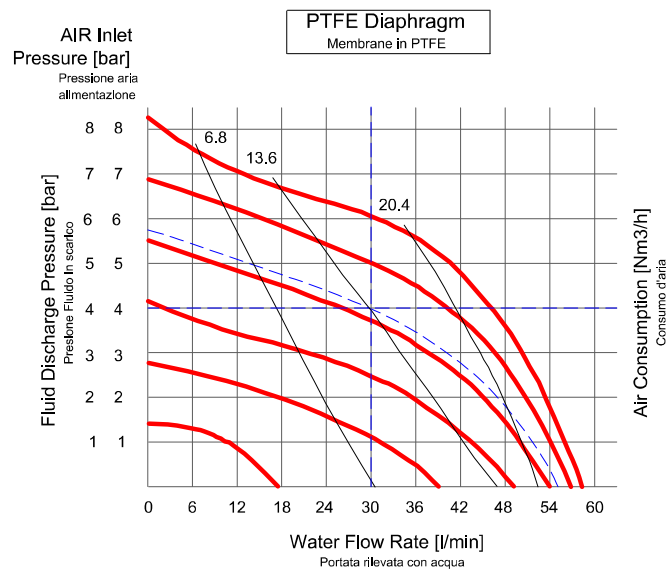

Per pompare 30 l/min ad una pressione di 4 bar, si richiedono di 5.7 bar di alimentazione con consumo d'aria di 13 Nm3/h.
To pump 30 lpm against a discharge pressure head of 4 bar, requires 5.7 bar and 13 Nm3/h air consumption.

DIMENSIONS

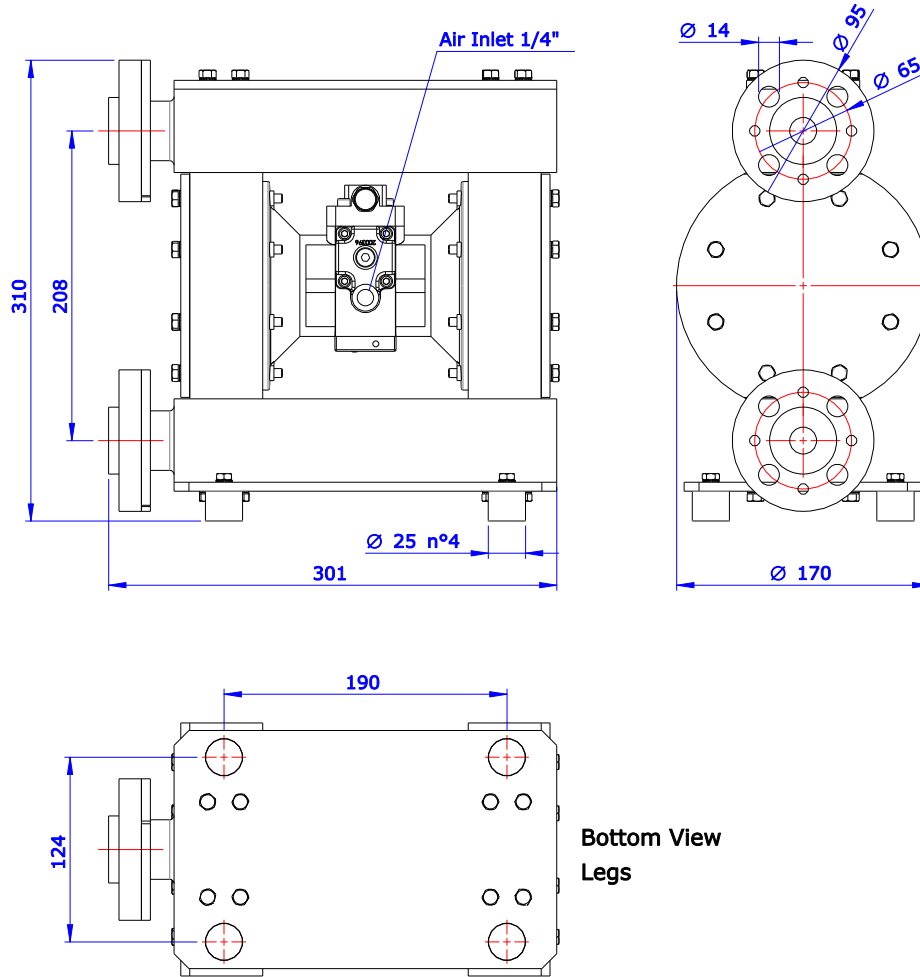

DN20 ALUMINUM (3/4")



PLUS

- Stainless Steel Screws
- Replaceable Inlet/Outlet valves
- Three Inlet and Three Outlet Ports for easier installations



TECHNICAL DATA

Adjustable Flow Rate	0÷72 l/min
Inlet/Outlet Ports	3/4" Gas Thread
Solids Max Size	3 mm
Max suction lift dry / wet	4,8 / 7,5 m
Air Inlet	1/4" Gas
Air Supply Pressure (Min / Max)	1 / 6.8 bar
Weight	8,5 Kg
Noise Level	<50 dB [A]
Diaphragms, gaskets, valves	Configurable based on the fluid to process

PERFORMANCE

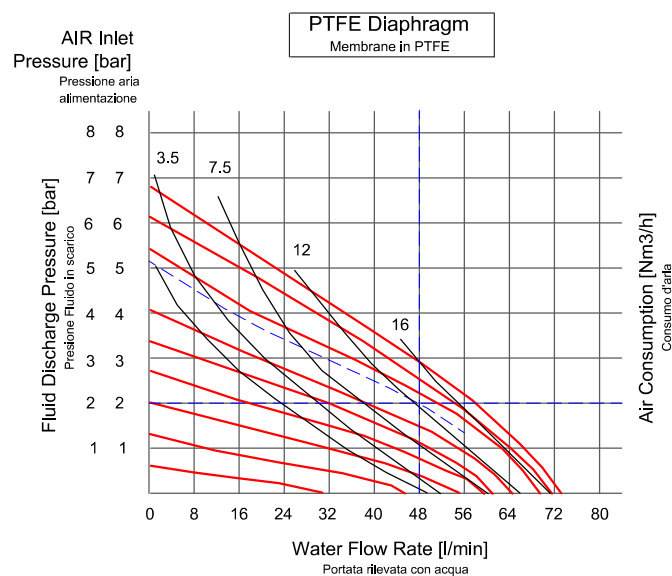

Per pompare 48 l/min ad una pressione di 2 bar, si richiedono di 5.1 bar di alimentazione con consumo d'aria di 12 Nm3/h.
To pump 48 lpm against a discharge pressure head of 2 bar, requires 5.1 bar and 12 Nm3/h air consumption.

DIMENSIONS

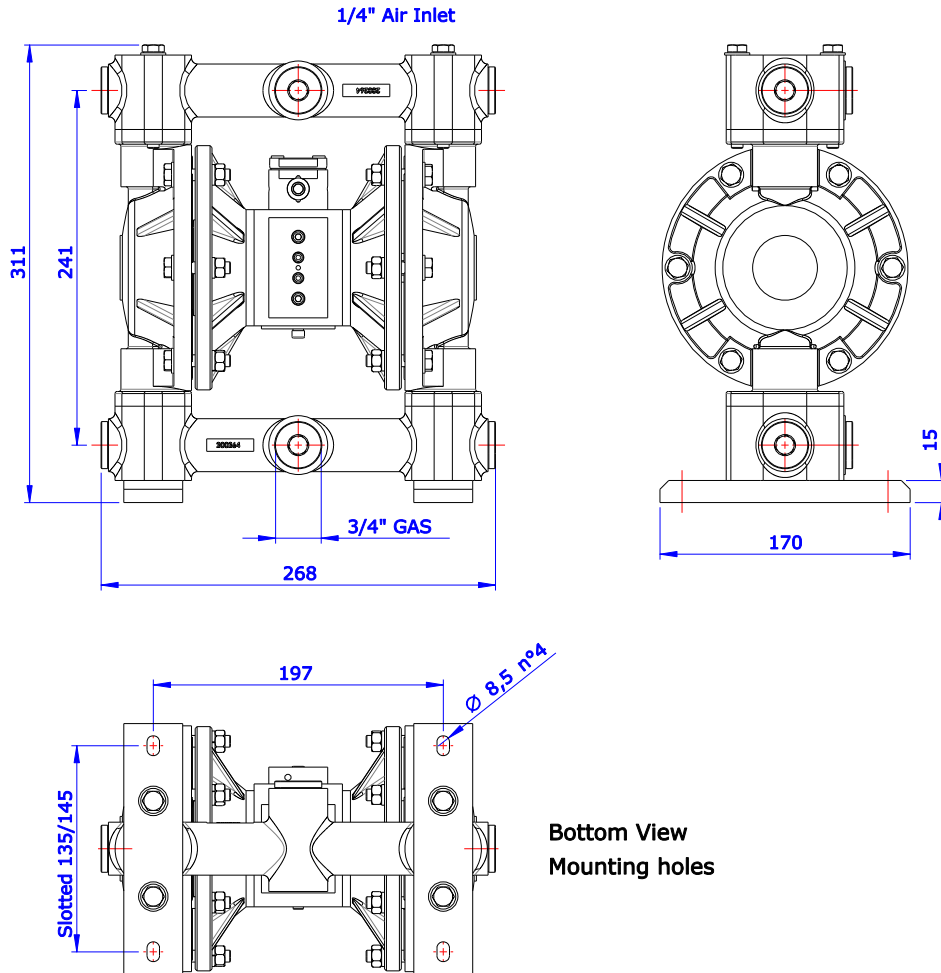

DN20 POLYPROPYLENE

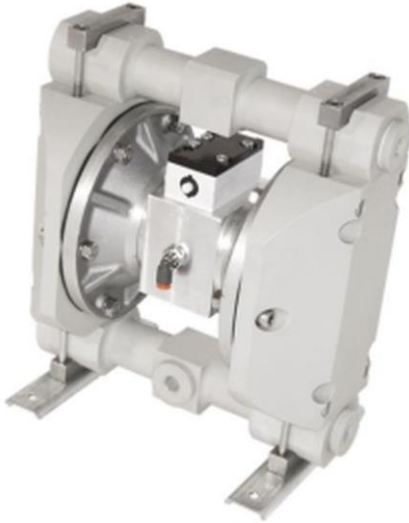

PLUS

- Stainless Steel Screws
- Replaceable Inlet/Outlet valves
- Three Inlet and Three Outlet Ports for easier installations
- Sturdy design, machined from solid



TECHNICAL DATA

Adjustable Flow Rate	0÷72 l/min
Inlet/Outlet Ports	3/4" Gas Thread
Solids Max Size	3 mm
Max suction lift dry / wet	4,8 / 7,5 m
Air Inlet	1/4" Gas
Air Supply Pressure (Min / Max)	1 / 6.8 bar
Weight	7,5 Kg
Noise Level	<50 dB [A]
Diaphragms, gaskets, valves	Configurable based on the fluid to process

PERFORMANCE

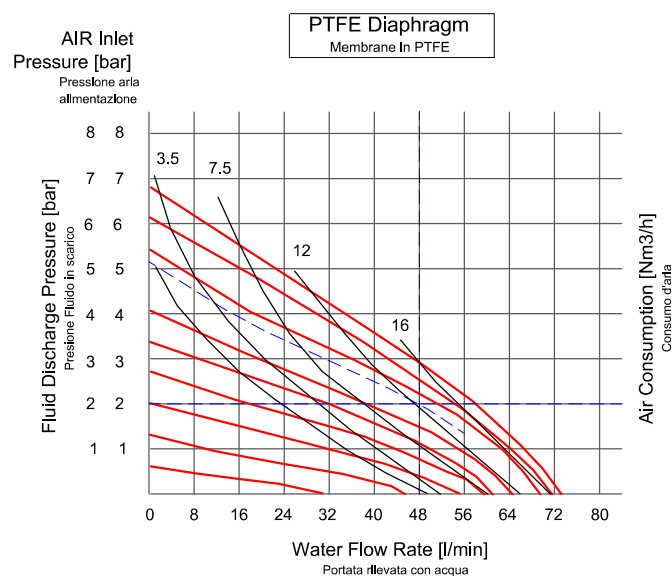

Per pompare 48 l/min ad una pressione di 2 bar, si richiedono di 5.1 bar di alimentazione con consumo d'aria di 12 Nm3/h.
To pump 48 lpm against a discharge pressure head of 2 bar, requires 5.1 bar and 12 Nm3/h air consumption.

DIMENSIONS

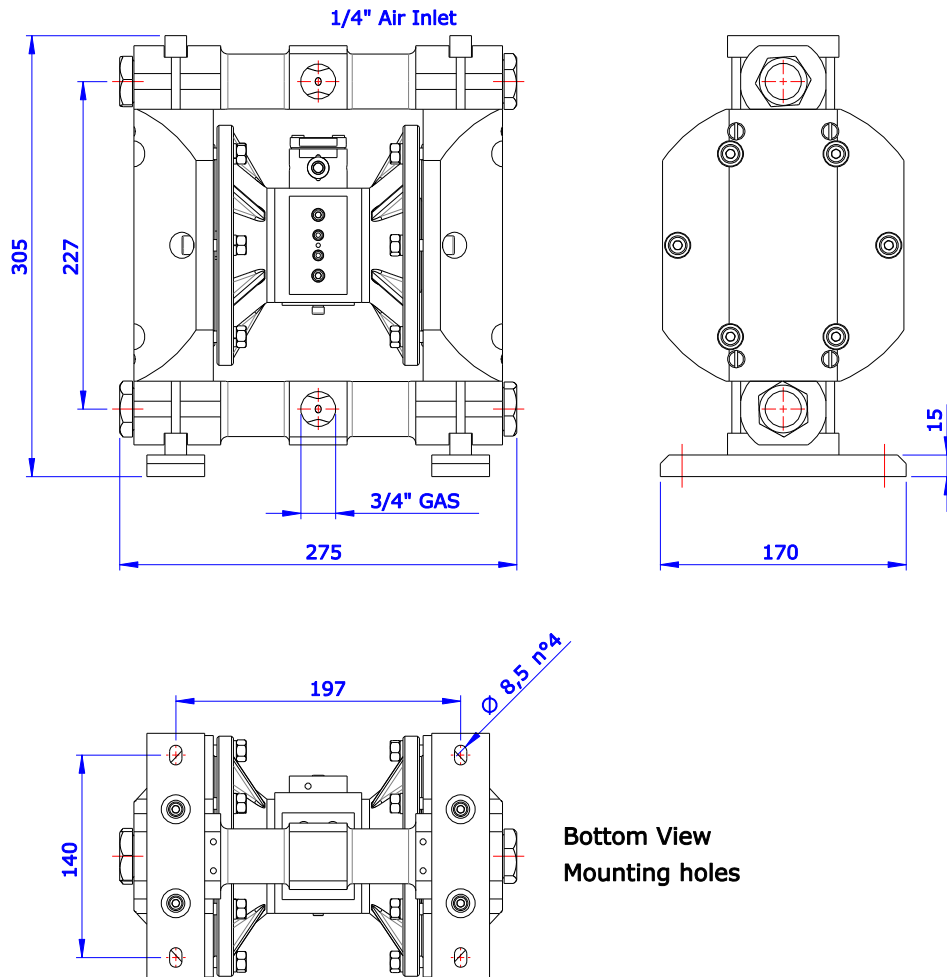

DN20 POLYETHYLENE(3/4")



PLUS

- Stainless Steel Screws
- Replaceable Inlet/Outlet valves
- Three Inlet and Three Outlet Ports for easier installations
- Sturdy design, machined from solid



TECHINCAL DATA

Adjustable Flow Rate	0÷72 l/min
Inlet/Outlet Ports	3/4" Gas Thread
Solids Max Size	3 mm
Max suction lift dry / wet	4,8 / 7,5 m
Air Inlet	1/4" Gas
Air Supply Pressure (Min / Max)	1 / 6.8 bar
Weight	7,5 Kg
Noise Level	<50 dB [A]
Diaphragms, gaskets, valves	Configurable based on the fluid to process

PERFORMANCE

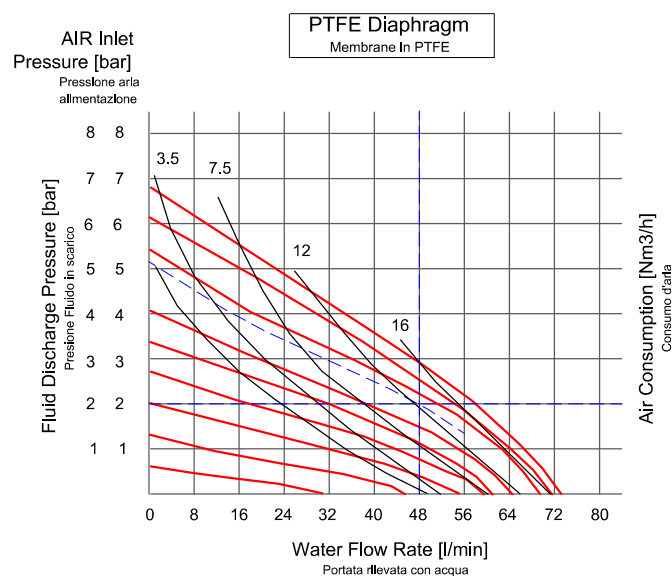

Per pompare 48 l/min ad una pressione di 2 bar, si richiedono di 5.1 bar di alimentazione con consumo d'aria di 12 Nm3/h.
To pump 48 lpm against a discharge pressure head of 2 bar, requires 5.1 bar and 12 Nm3/h air consumption.

DIMENSIONS

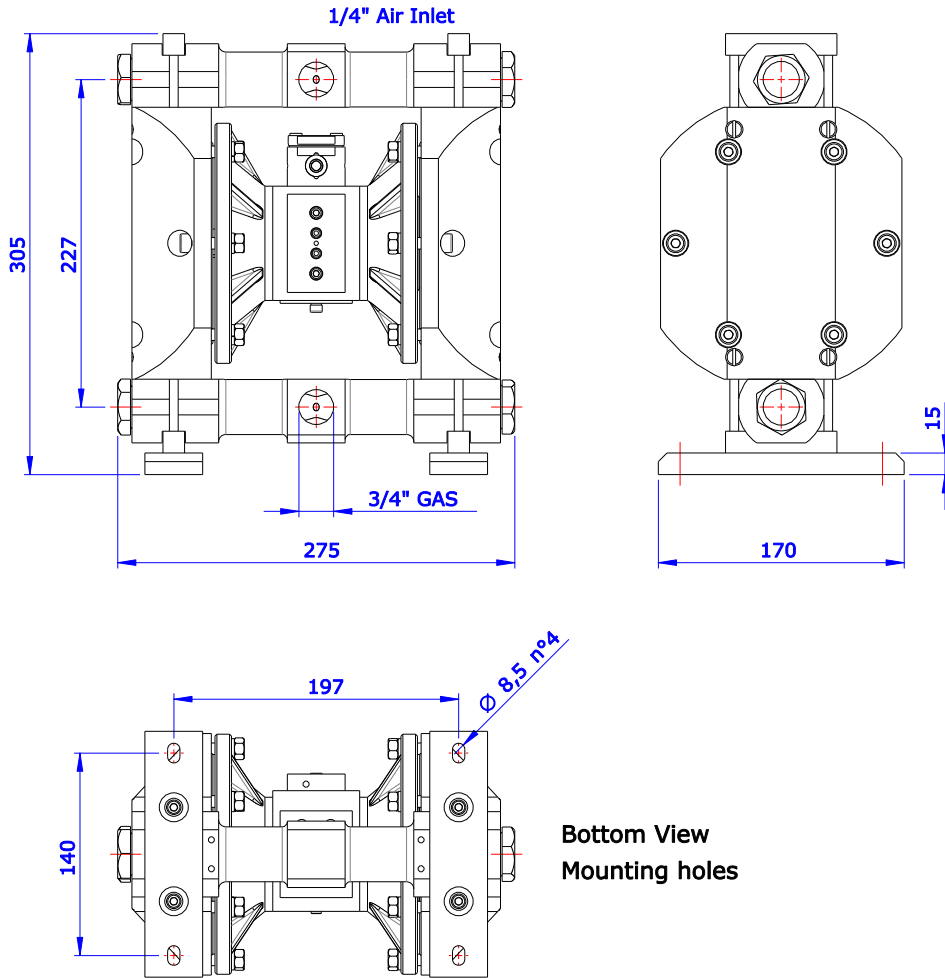

DN25 ALUMINUM (1")



PLUS

- Stainless Steel Screws
- Replaceable Inlet/Outlet valves
- Three Inlet and Three Outlet Ports for easier installations



TECHINCAL DATA

Adjustable Flow Rate	0÷120 l/min (PTFE Diaphragms) 0÷140 l/min (EPDM Diaphragms)
Inlet/Outlet Ports	1" Gas Thread (3+3)
Solids Max Size	5 mm
Max suction lift dry / wet	4 / 7 m
Air Inlet	3/8" Gas
Air Supply Pressure (Min / Max)	1 / 6.8 bar
Weight	11 Kg
Noise Level	<50 dB [A]
Diaphragms, gaskets, valves	Configurable based on the fluid to process

PERFORMANCE

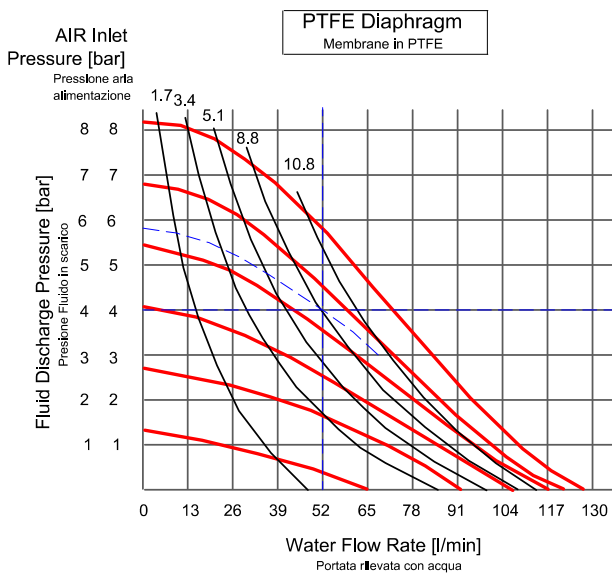

Per pompare 52 l/min ad una pressione di 4 bar, si richiedono di 5,8 bar di alimentazione con consumo d'aria di 8,8 Nm3/h.
To pump 52 lpm against a discharge pressure head of 4 bar, requires 5,8 bar and 68 Nm3/h air consumption.

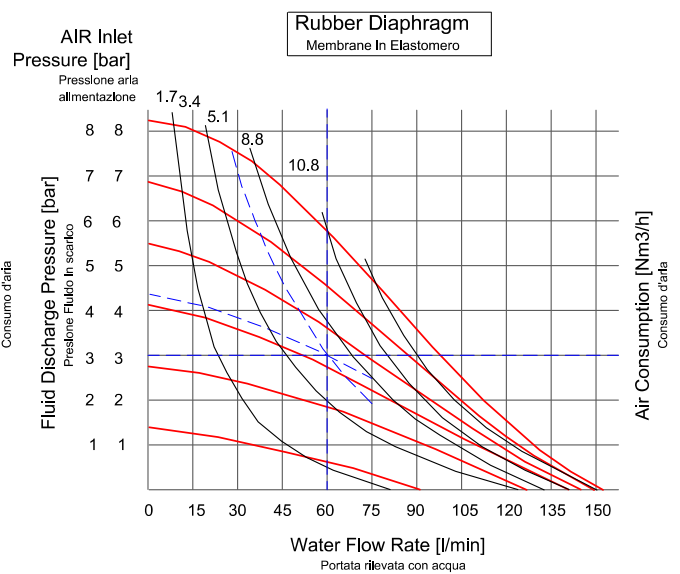

Per pompare 60 l/min ad una pressione di 3 bar, si richiedono di 4,3 bar di alimentazione con consumo d'aria di 8,8 Nm3/h.
To pump 60 lpm against a discharge pressure head of 3 bar, requires 4,3 bar and 45 Nm3/h air consumption.

DIMENSIONS

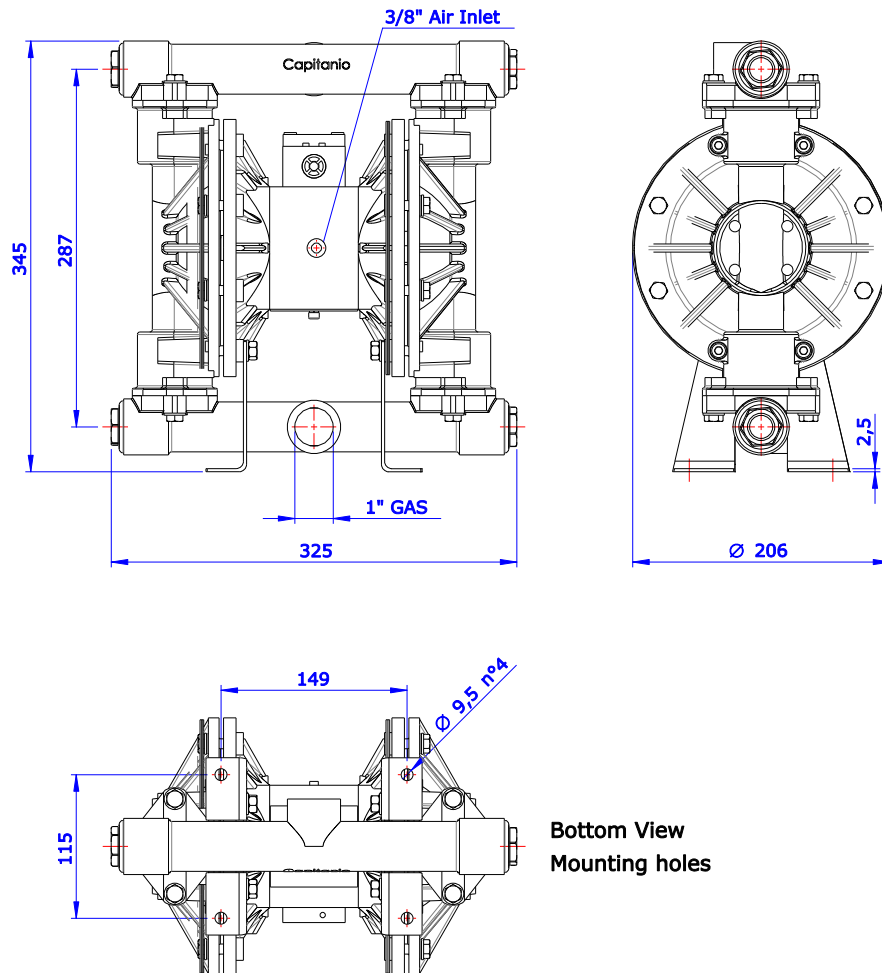

Bottom View
Mounting holes

DN25 POLYPROPYLENE (1")



PLUS

- Stainless Steel Screws
- Replaceable Inlet/Outlet valves
- Three Inlet and Three Outlet Ports for easier installations
- Sturdy design, machined from solid



TECHINCAL DATA

Adjustable Flow Rate	0÷120 l/min (PTFE Diaphragms) 0÷140 l/min (EPDM Diaphragms)
Inlet/Outlet Ports	1" Gas Thread (3+3)
Solids Max Size	5 mm
Max suction lift dry / wet	4 / 7 m
Air Inlet	3/8" Gas
Air Supply Pressure (Min / Max)	1 / 6.8 bar
Weight	13,5 Kg
Noise Level	<50 dB [A]
Diaphragms, gaskets, valves	Configurable based on the fluid to process

PERFORMANCE

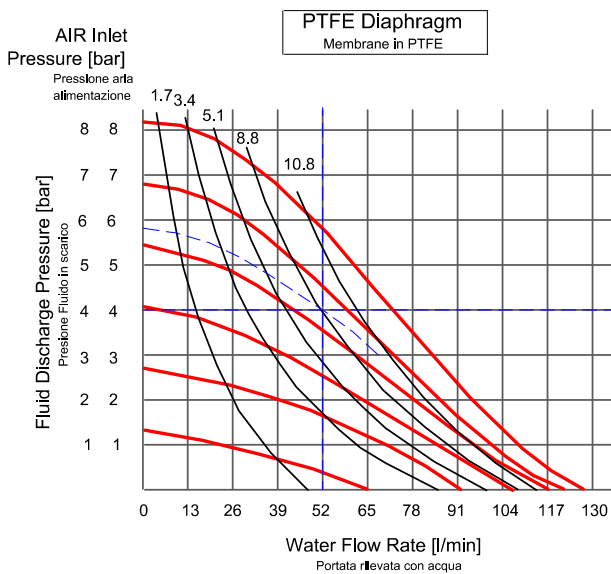

Per pompare 52 l/min ad una pressione di 4 bar, si richiedono di 5,8 bar di alimentazione con consumo d'aria di 8,8 Nm3/h.
To pump 52 lpm against a discharge pressure head of 4 bar, requires 5,8 bar and 8,8 Nm3/h air consumption.

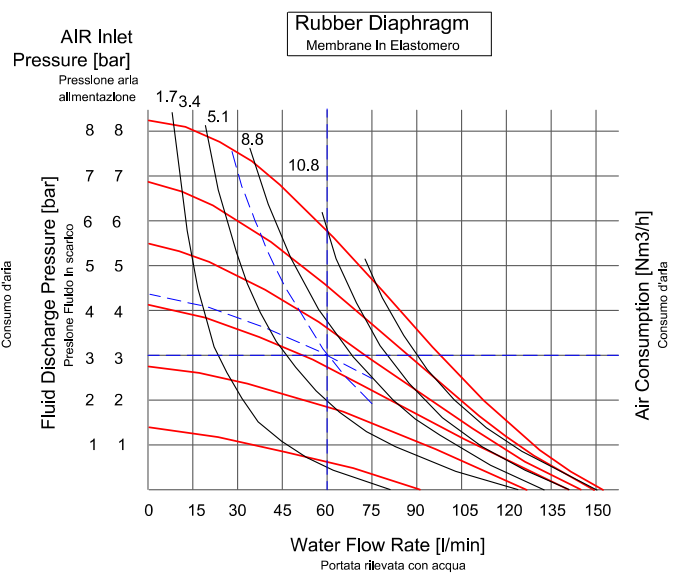

Per pompare 60 l/min ad una pressione di 3 bar, si richiedono di 4,3 bar di alimentazione con consumo d'aria di 4,5 Nm3/h.
To pump 60 lpm against a discharge pressure head of 3 bar, requires 4,3 bar and 4,5 Nm3/h air consumption.

DIMENSIONS

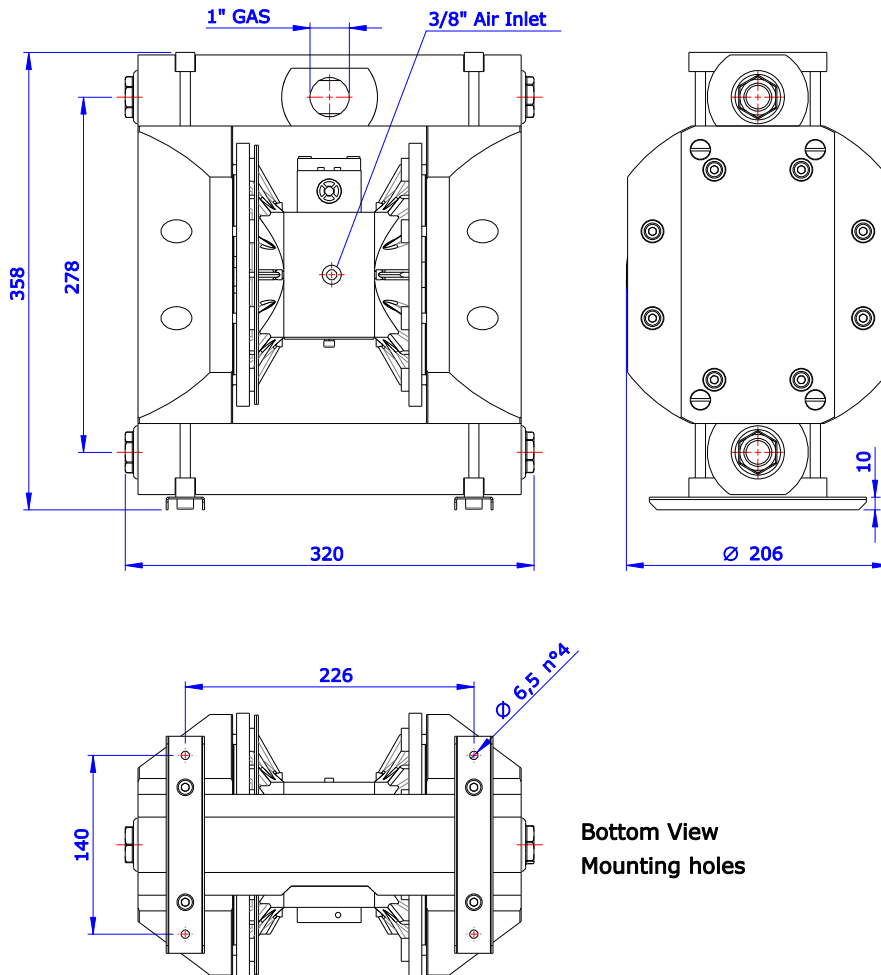

DN25 PTFE (1")



PLUS

- Fluid Side entirely in PTFE
- Stainless Steel Screws



TECHNICAL DATA

Adjustable Flow Rate	0÷120 l/min (PTFE Diaphragms) 0÷140 l/min (EPDM Diaphragms)
Inlet/Outlet Ports	1" DIN Flange
Solids Max Size	5 mm
Max suction lift dry / wet	4 / 7 m
Air Inlet	3/8" Gas
Air Supply Pressure (Min / Max)	1 / 6.8 bar
Weight	26,5 Kg
Noise Level	<50 dB [A]
Diaphragms, gaskets, valves	Configurable based on the fluid to process

PERFORMANCE

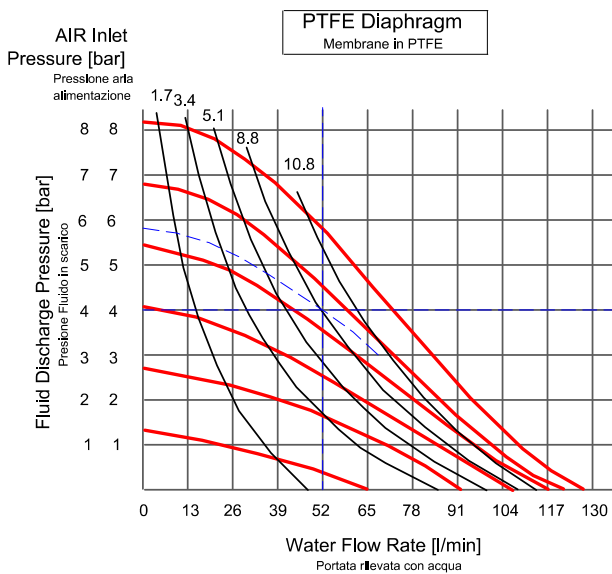

Per pompare 52 l/min ad una pressione di 4 bar, si richiedono di 5,8 bar di alimentazione con consumo d'aria di 8,8 Nm3/h.
To pump 52 lpm against a discharge pressure head of 4 bar, requires 5,8 bar and 8,8 Nm3/h air consumption.

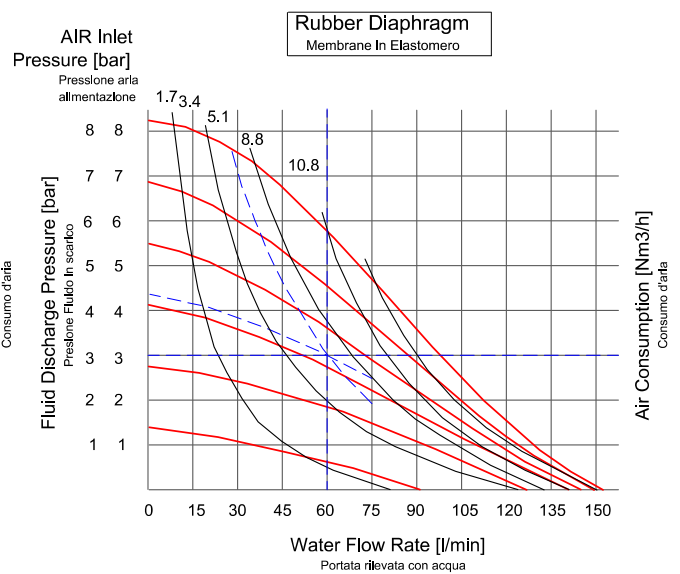

Per pompare 60 l/min ad una pressione di 3 bar, si richiedono di 4,3 bar di alimentazione con consumo d'aria di 8,8 Nm3/h.
To pump 60 lpm against a discharge pressure head of 3 bar, requires 4,3 bar and 4,5 Nm3/h air consumption.

DIMENSIONS

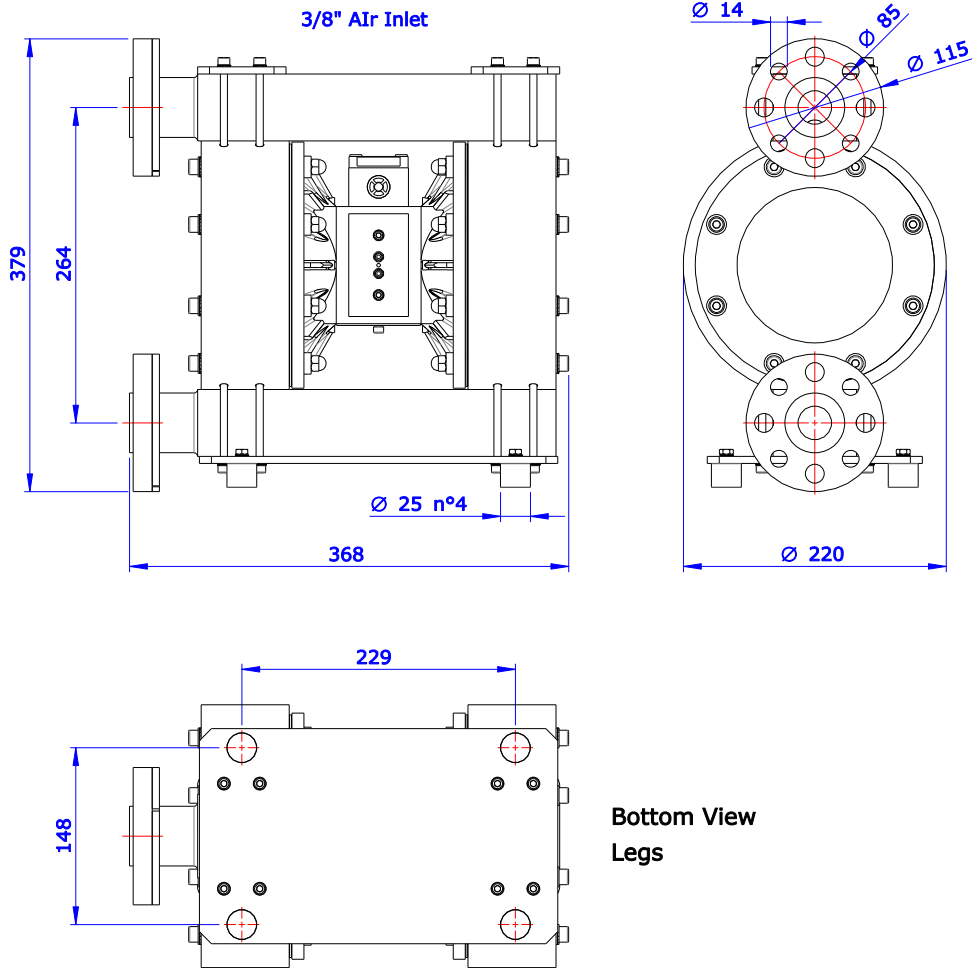

DN28 POLYPROPYLENE (1")



PLUS

- Stainless Steel Screws
- Replaceable Inlet/Outlet valves
- 180° Rotatable Inlet/Outlet Ports



TECHNICAL DATA

Adjustable Flow Rate

Inlet/Outlet Ports

Solids Max Size

Max suction lift dry / wet

Air Inlet

Air Supply Pressure (Min / Max)

Weight

Noise Level

Diaphragms, gaskets, valves

0÷120 l/min (PTFE Diaphragms)

0÷140 l/min (EPDM Diaphragms)

1" Gas Thread

5 mm

4 / 7 m

3/8" Gas

1 / 6.8 bar

12,5 Kg

<50 dB [A]

Configurable based on the fluid to process

PERFORMANCE

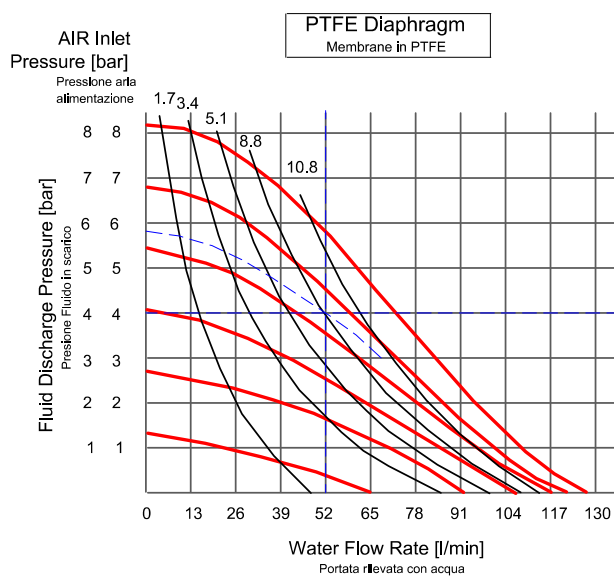

Per pompare 52 l/min ad una pressione di 4 bar, si richiedono di 5,8 bar di alimentazione con consumo d'aria di 8,8 Nm3/h.
To pump 52 lpm against a discharge pressure head of 4 bar, requires 5,8 bar and 68 Nm3/h air consumption.

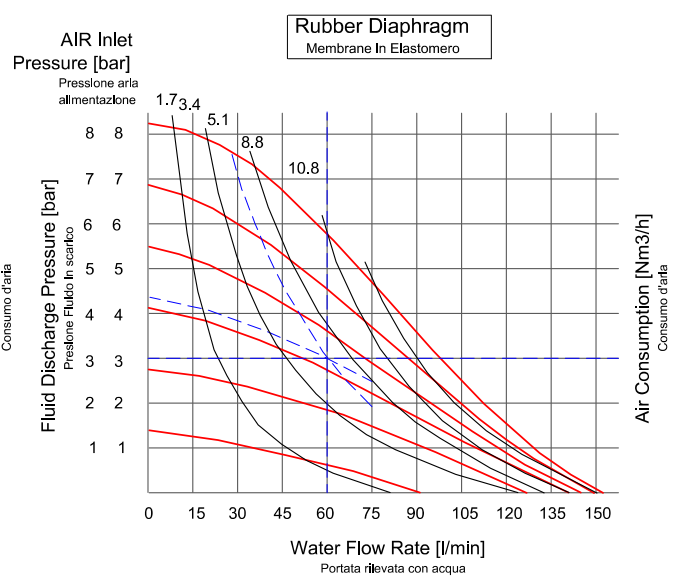

Per pompare 60 l/min ad una pressione di 3 bar, si richiedono di 4,3 bar di alimentazione con consumo d'aria di 8,8 Nm3/h.
To pump 60 lpm against a discharge pressure head of 3 bar, requires 4,3 bar and 45 Nm3/h air consumption.

DIMENSIONS

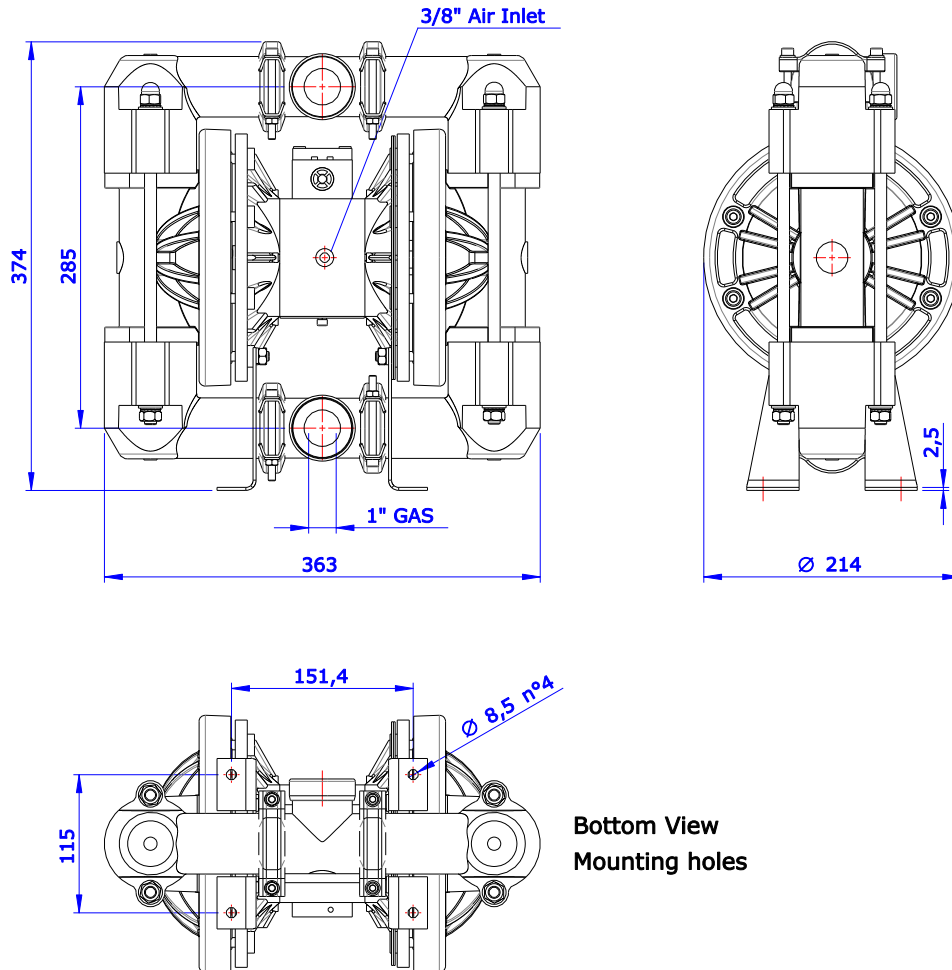

Bottom View
Mounting holes

DN28 PVDF (1")



PLUS

- Stainless Steel Screws
- Replaceable Inlet/Outlet valves
- 180° Rotatable Inlet/Outlet Ports



TECHINCAL DATA

Adjustable Flow Rate

Inlet/Outlet Ports

Solids Max Size

Max suction lift dry / wet

Air Inlet

Air Supply Pressure (Min / Max)

Weight

Noise Level

Diaphragms, gaskets, valves

0÷120 l/min (PTFE Diaphragms)

0÷140 l/min (EPDM Diaphragms)

1" Gas Thread

5 mm

4 / 7 m

3/8" Gas

1 / 6.8 bar

12,5 Kg

<50 dB [A]

Configurable based on the fluid to process

PERFORMANCE

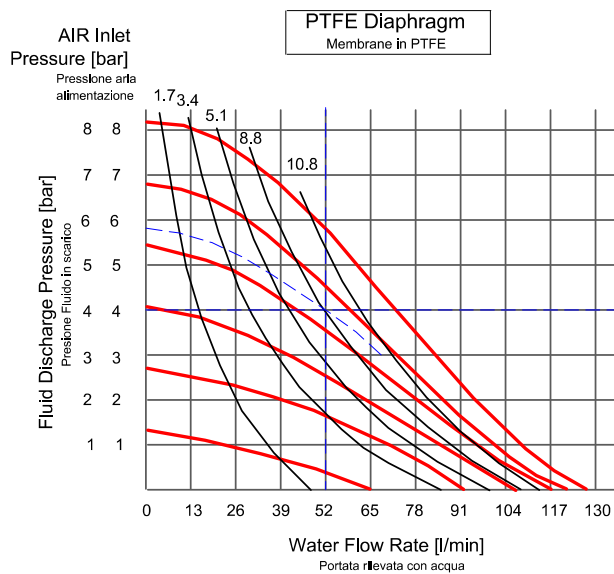

Per pompare 52 l/min ad una pressione di 4 bar, si richiedono di 5,8 bar di alimentazione con consumo d'aria di 8,8 Nm³/h.
To pump 52 lpm against a discharge pressure head of 4 bar, requires 5,8 bar and 68 Nm³/h air consumption.

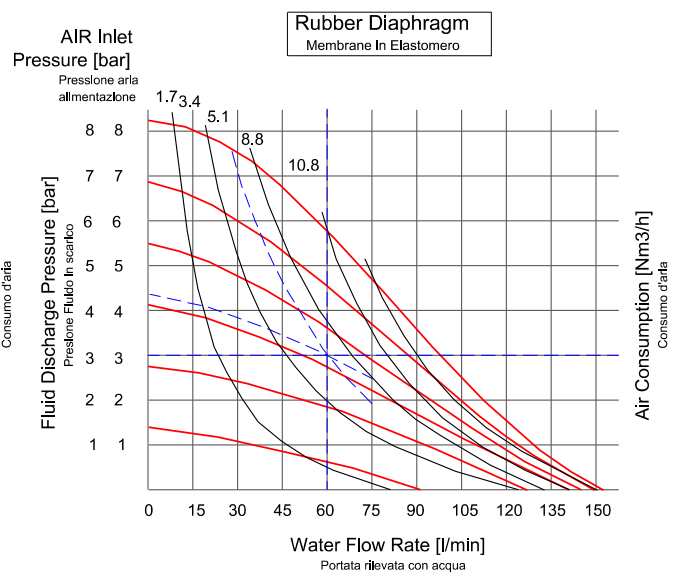

Per pompare 60 l/min ad una pressione di 3 bar, si richiedono di 4,3 bar di alimentazione con consumo d'aria di 8,8 Nm³/h.
To pump 60 lpm against a discharge pressure head of 3 bar, requires 4,3 bar and 45 Nm³/h air consumption.

DIMENSIONS

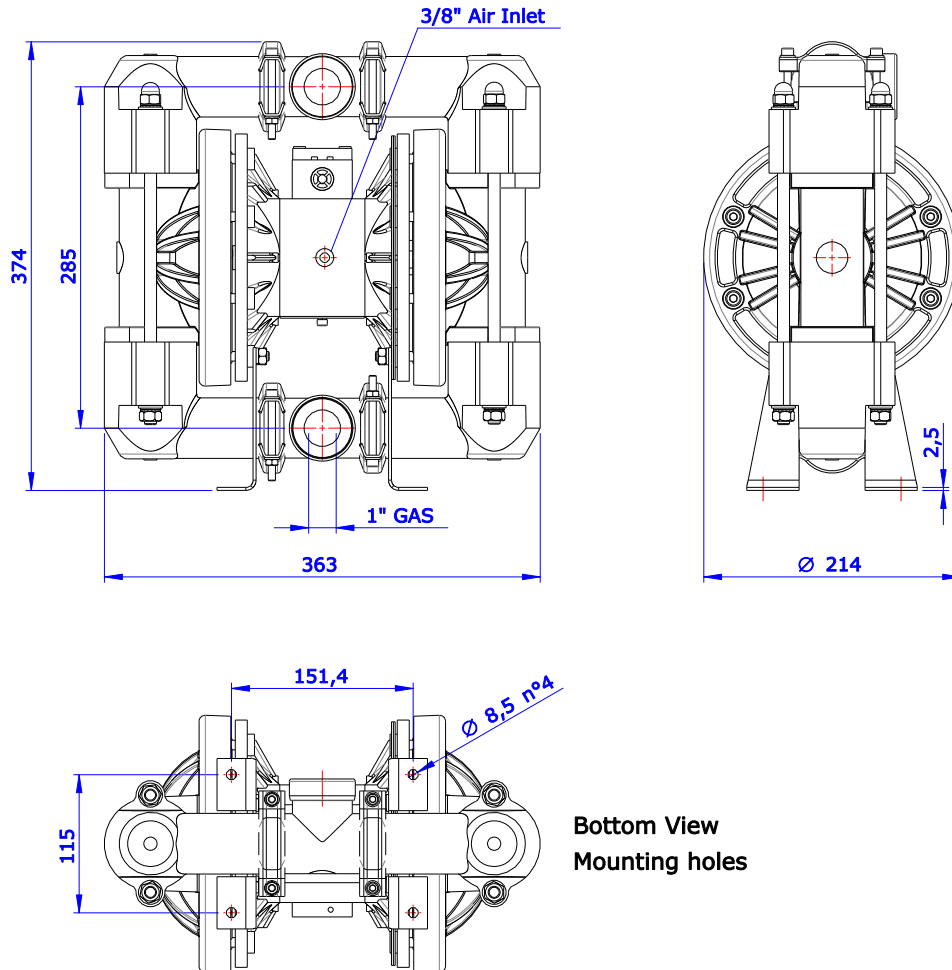

DN40 ALUMINUM (1" 1/2")



PLUS

- Stainless Steel Screws
- Replaceable Inlet/Outlet valves



TECHINCAL DATA

Adjustable Flow Rate	0÷320 l/min (PTFE Diaphragms) 0÷416 l/min (EPDM Diaphragms)
Inlet/Outlet Ports	1" 1/2" Gas Thread
Solids Max Size	8 mm
Max suction lift dry / wet	3,8 / 9,5 m
Air Inlet	3/8" Gas
Air Supply Pressure (Min / Max)	1 / 6.8 bar
Weight	23,5 Kg
Noise Level	<50 dB [A]
Diaphragms, gaskets, valves	Configurable based on the fluid to process

PERFORMANCE

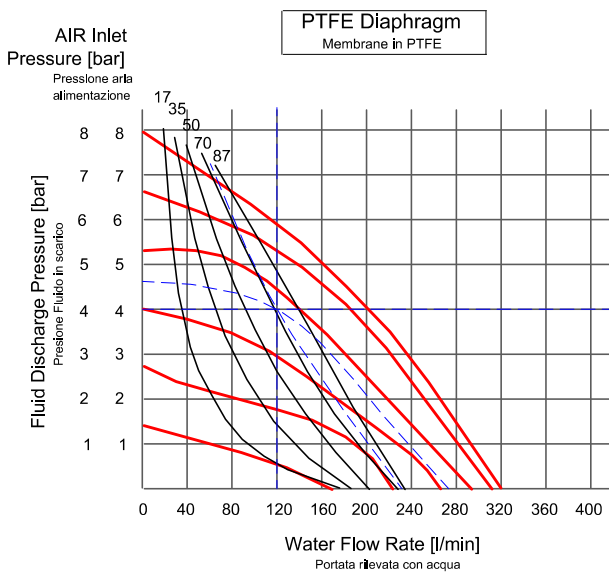

Per pompare 120 l/min ad una pressione di 4 bar, si richiedono di 4,8 bar di alimentazione con consumo d'aria di 87 m3/h.
To pump 120 l/min against a discharge pressure head of 4 bar, requires 4.8 bar and 87 m3/h air consumption.

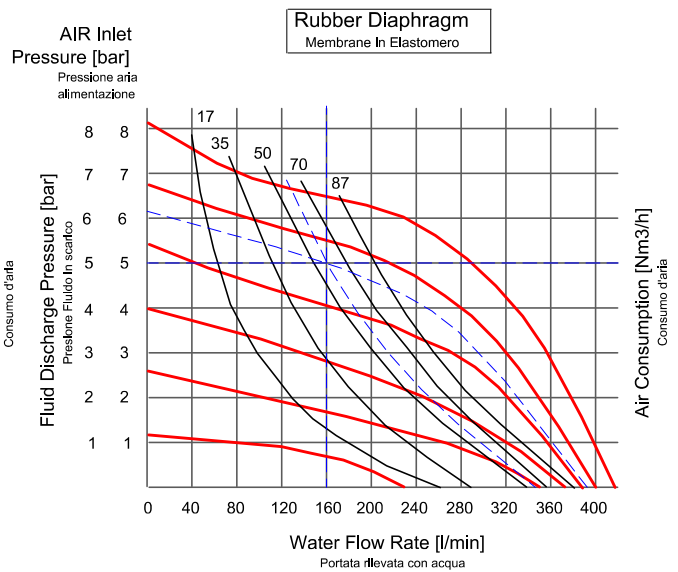

Per pompare 160 l/min ad una pressione di 5 bar, si richiedono di 6,2 bar di alimentazione con consumo d'aria di 70 m3/h.
To pump 160 l/min against a discharge pressure head of 5 bar, requires 6.2 bar and 70 m3/h air consumption.

DIMENSIONS

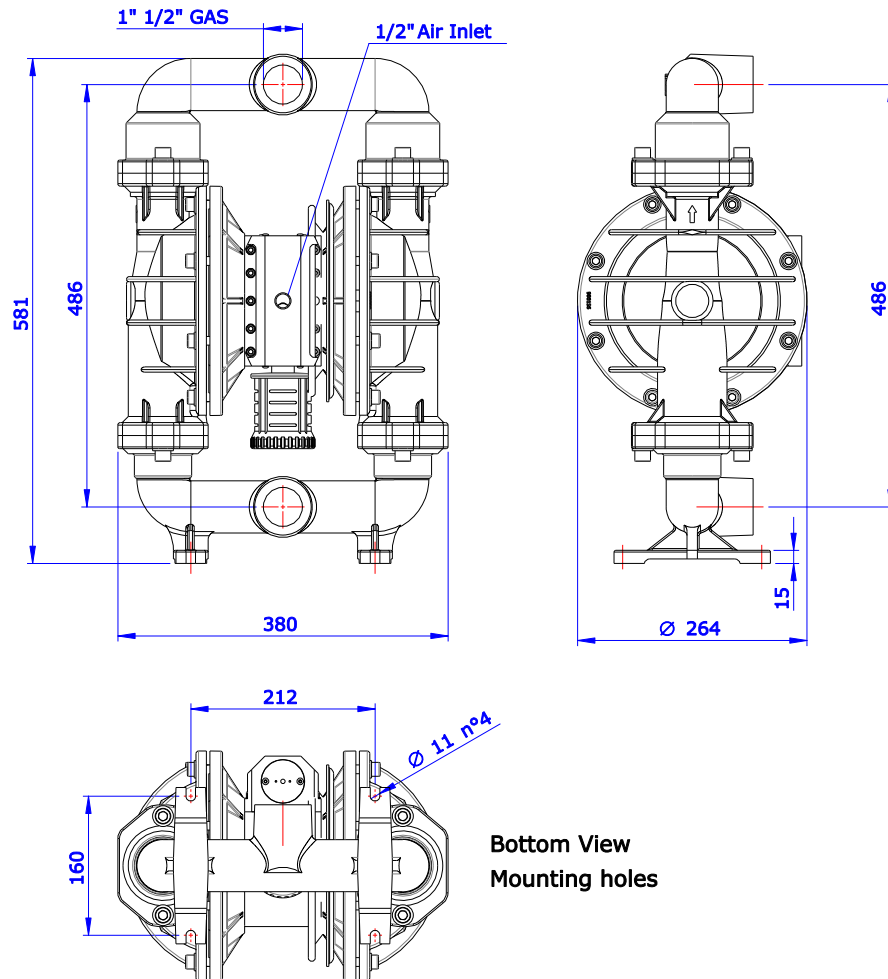

DN50 POLYPROPYLENE (2")



PLUS

- Stainless Steel Screws
- Replaceable Inlet/Outlet valves



TECHNICAL DATA

Adjustable Flow Rate	0÷540 l/min (PTFE Diaphragms) 0÷600 l/min (EPDM Diaphragms)
Inlet/Outlet Ports	2" Gas Thread
Solids Max Size	8 mm
Max suction lift dry / wet	3,8 / 9,5 m
Air Inlet	3/8" Gas
Air Supply Pressure (Min / Max)	1 / 6.8 bar
Weight	31 Kg
Noise Level	<50 dB [A]
Diaphragms, gaskets, valves	Configurable based on the fluid to process

PERFORMANCE

DIMENSIONS

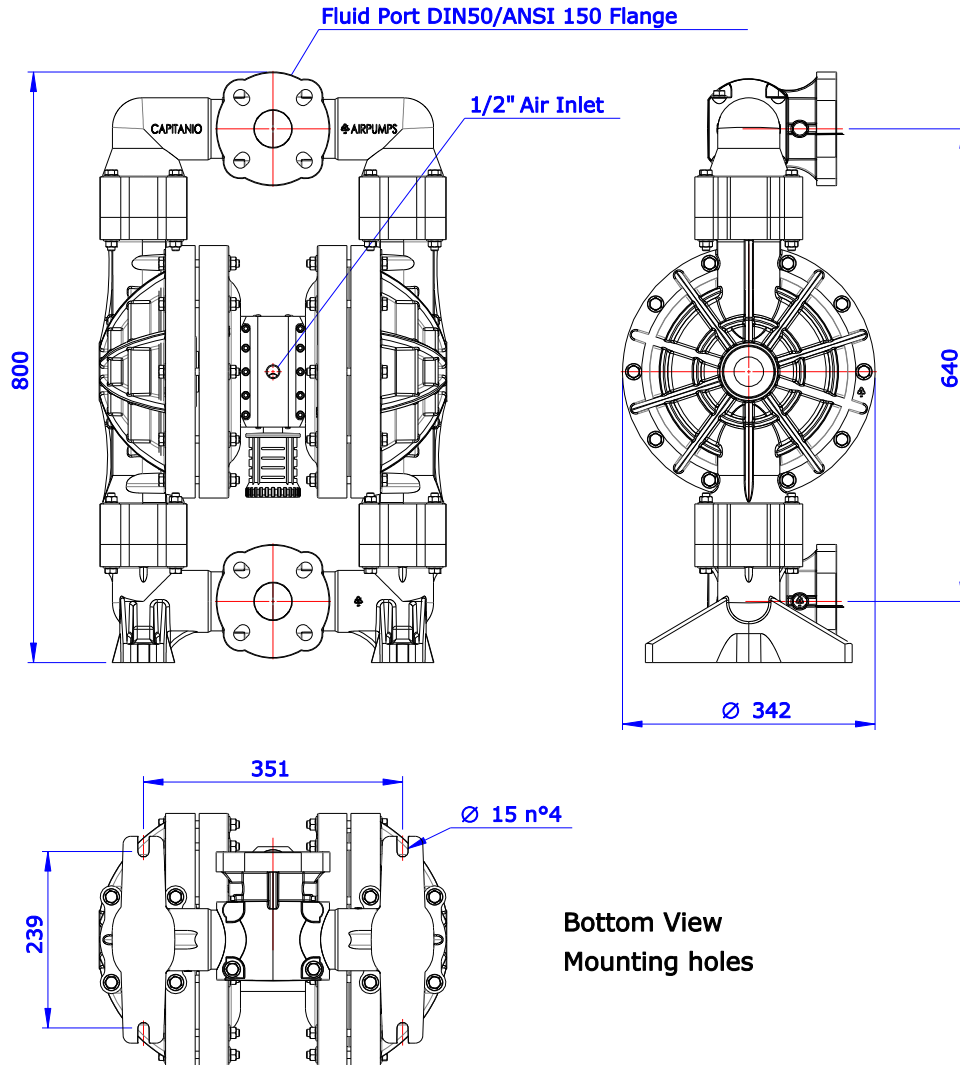

DN50 PVDF (2")



PLUS

- Stainless Steel Screws
- Replaceable Inlet/Outlet valves



TECHINCAL DATA

Adjustable Flow Rate	0÷540 l/min (PTFE Diaphragms) 0÷600 l/min (EPDM Diaphragms)
Inlet/Outlet Ports	2" Gas Thread
Solids Max Size	8 mm
Max suction lift dry / wet	3,8 / 9,5 m
Air Inlet	3/8" Gas
Air Supply Pressure (Min / Max)	1 / 6.8 bar
Weight	35 Kg
Noise Level	<50 dB [A]
Diaphragms, gaskets, valves	Configurable based on the fluid to process

PERFORMANCE

DIMENSIONS

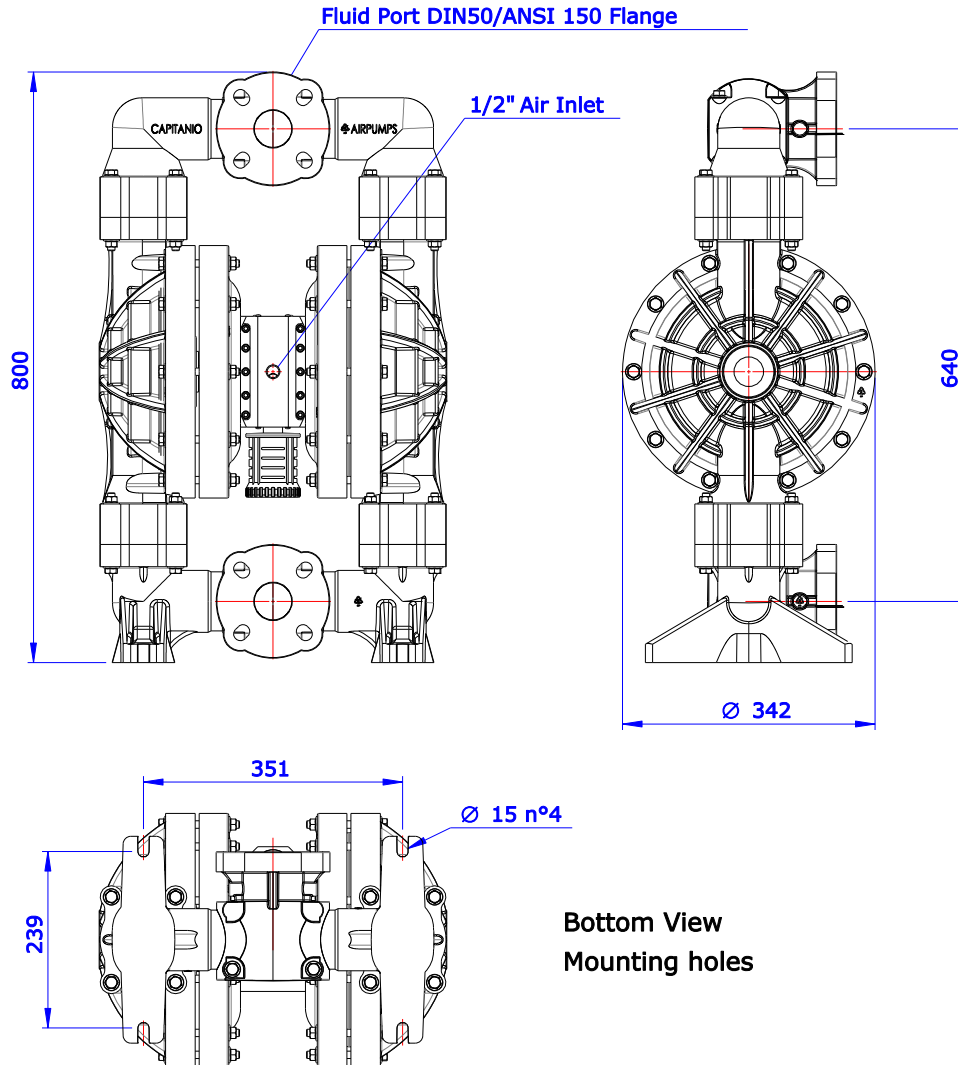

DN50 STAINLESS STEEL (1/2")



PLUS

- Wet parts in Stainless Steel AISI304 or AISI316L
- CIP - Cleaning in Place
- Replaceable Inlet/Outlet valves
- Includes a Wheeled Stainless Steel Kart, 360° Adjustable Inlet and Outlet Ports



TECHNICAL DATA

Adjustable Flow Rate	0÷38 l/min
Inlet/Outlet Ports	1/2" Gas Thread (4+4 Ports)
Solids Max Size	2 mm
Max suction lift dry / wet	4,5 / 7 m
Air Inlet	1/4" Gas
Air Supply Pressure (Min / Max)	1 / 6.8 bar
Weight	13 Kg
Noise Level	<50 dB [A]
Diaphragms, gaskets, valves	Configurable based on the fluid to process

PERFORMANCE

DIMENSIONS

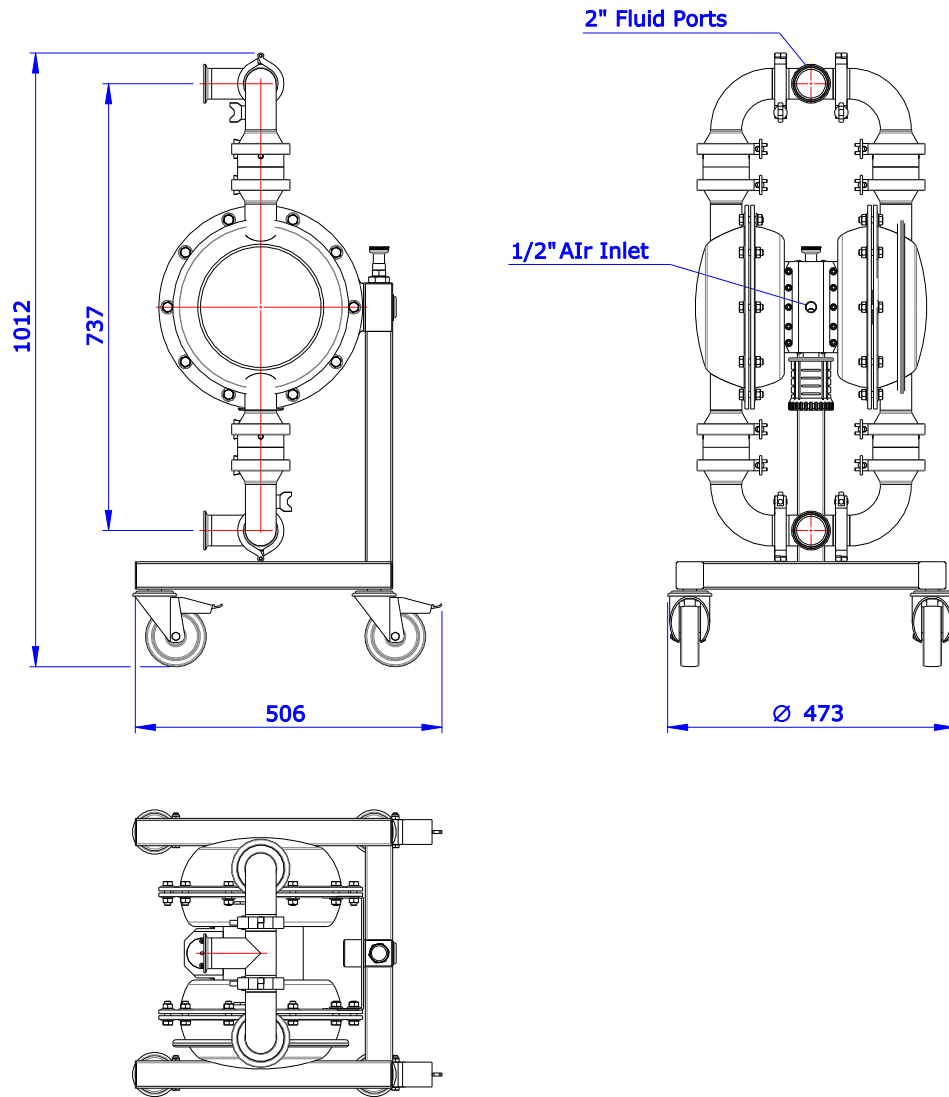

REVERSE



WHAT IS A REVERSE

The Reverse is a **Capitanio Patented device**. When applied to diaphragm pumps or other types of pump, it allows to invert the flow direction; manually or pneumatically operated, inlet and outlet are reversed.

REVERSIBLE PUMPS

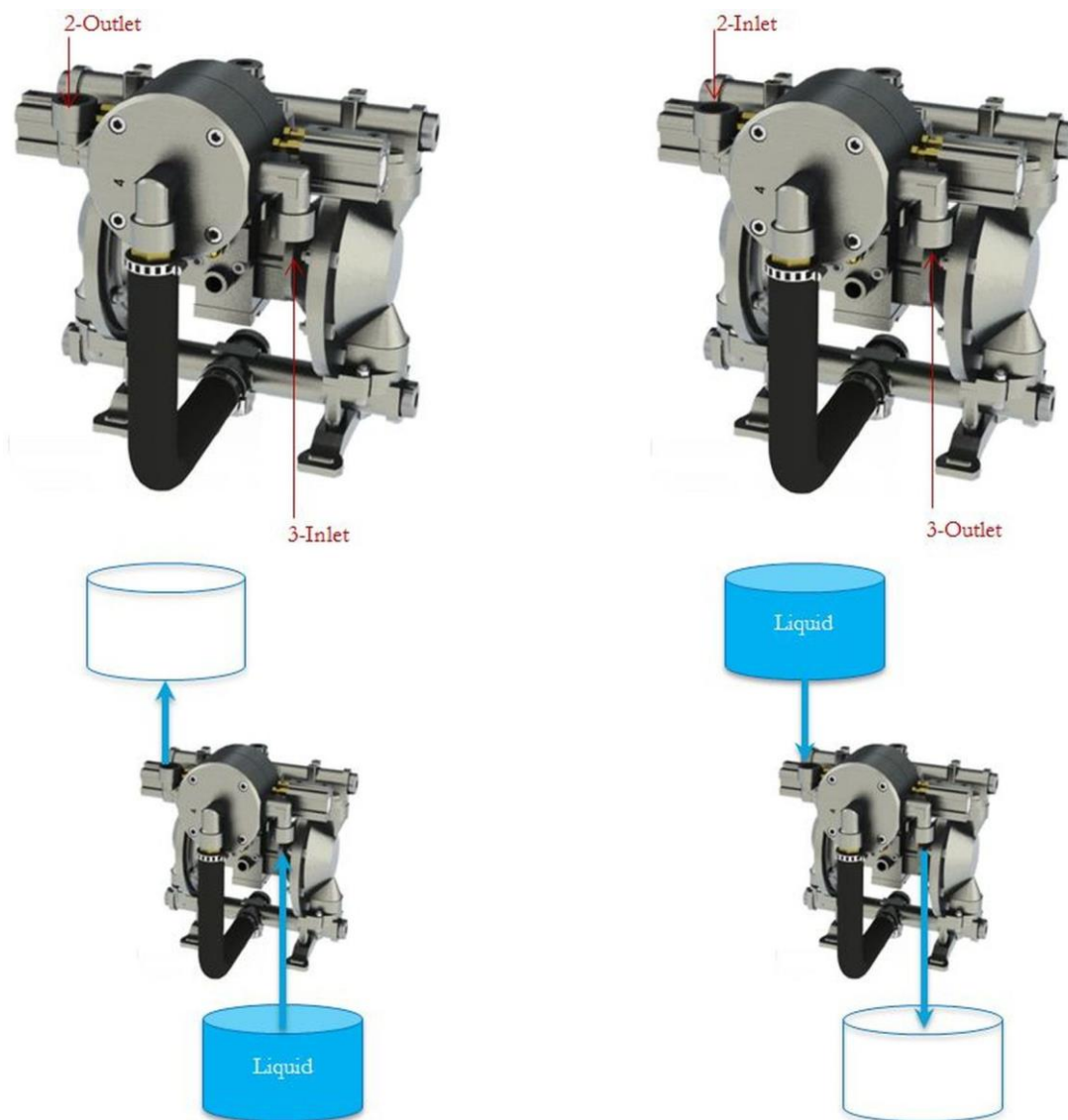

Phase A: Inlet from Port 3, Outlet from Port 2

Phase B: Inlet from Port 2, Outlet from Port 3

For more information see "Valves, Pulsation Dampeners and Reverse" Catalogue

CUSTOMIZATION

FOR EVERY MODEL

Double Inlet / Double Outlet

With this customization one pump can process two different fluids simultaneously.



Different types of material

Components in contact with the fluid can be manufactured in different types of material to fulfill special chemical and/or temperature requirements.



Suggested materials:

- Polypropylene
- PVDF
- PTFE
- PVC
- Polyethylene
- Stainless Steel

FOR EVERY MODEL

Air Side protective coatings

In some applications, for example when the environment has chemically aggressive fumes, or there's the risk of spills, the parts not in contact with the fluid can be protected with a protective coating.

Example of covers:

- Teflon
- Nickel
- Paint
- Cathaphoresis





ACCESSORIES

AIR TREATMENT KIT

Pressure regulators, manometers, filters, for a correct supply of the pneumatic pump



BEAT COUNTER

Every pump can be provided with a beat counter

MONITORING DEVICE

Every pump can be provided with an electronic monitoring device, which can be used to operate the pump, diagnosis or statistics.

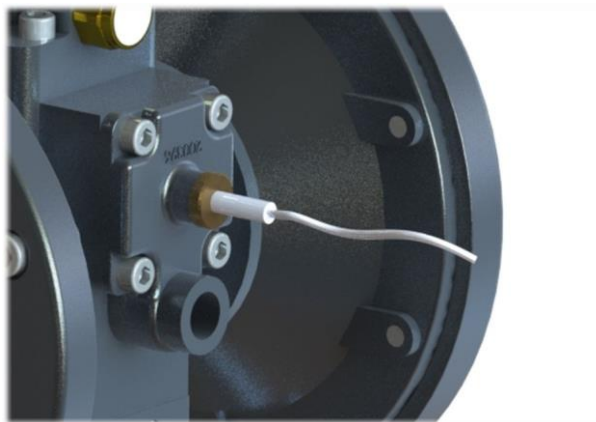

PULSATION DAMPENERS

Both electric and pneumatic reciprocating pumps, such as double diaphragm and piston ones, generate a pulsating flow. Sometimes those pulsations compromise the result of the production process, therefore, are needed some precautionary measures to lower those flow variations.

Pulsation dampeners are devices that help transform the pulsating flow into a more linear and steady flow.



DYNAMIC PULSATION DAMPENERS - NO PULS

A Capitanio Airpumps Patented product. The only double diaphragm pulsation dampener that processes 100% of the fluid.

The dynamic pulsation dampener is a device that actively compensates the pulsations of reciprocating pumps, like diaphragm or piston pumps.

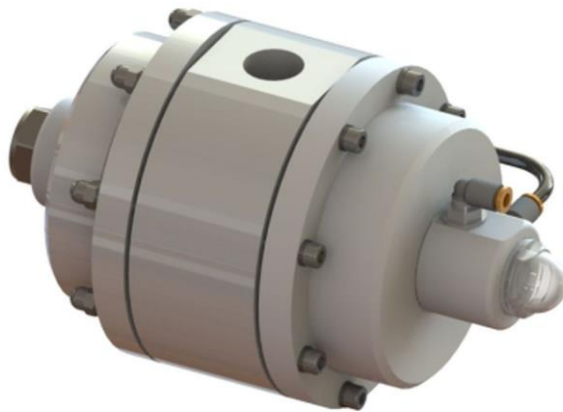

For more information see "**Valves, Pulsation Dampeners and Reverse**" Catalogue

STATIC PULSATION DAMPENERS

2,5 LITERS STATIC PULSATION DAMPENER, IN STAINLESS STEEL

Stainless Steel tank, inspectionable, with manometer. Capacity 2,5 liters. Ports: 1/2" or 3/4" Gas.

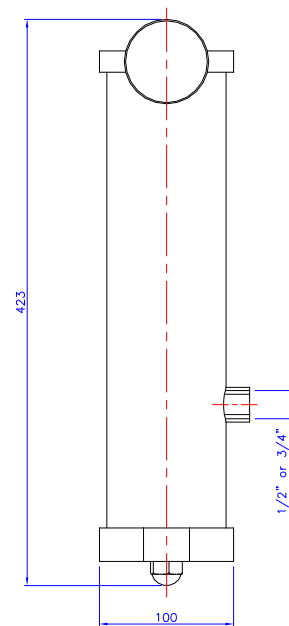

1 LITER STATIC PULSATION DAMPENER, IN STAINLESS STEEL

Stainless Steel tank, inspectionable. Capacity 1 liter. 1/2" Gas Port.

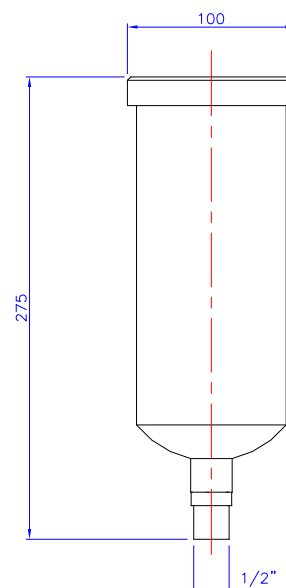

0,5 LITER STATIC PULSATION DAMPENER

Steel Tank. Capacity 0,5 liter. 1/2" Gas Port.

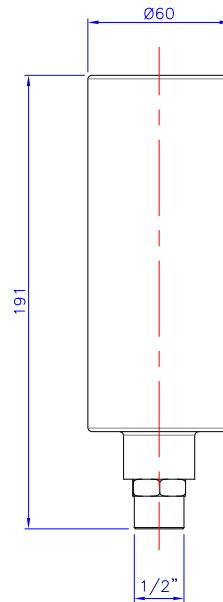

0,5 LITER STATIC PULSATION DAMPENER, IN STAINLESS STEEL

Stainless Steel tank, inspectionable. Capacity 0,5 liter. 1/2" Gas Ports.

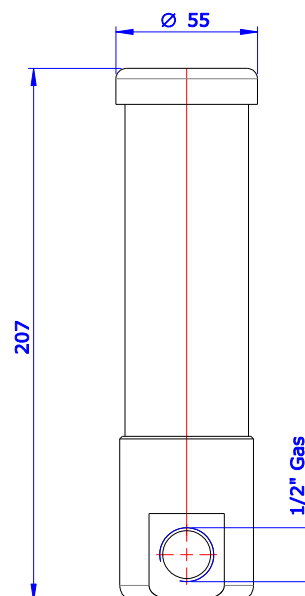

INLET FILTERS

BELL FILTER

Standard body in Aluminum, can be produced in other materials. Filter net in nylon with different and interchangeable mesh sizes (180/250/600 μ m). Available with hose connection, Stainless Steel tube, or rubber hose.

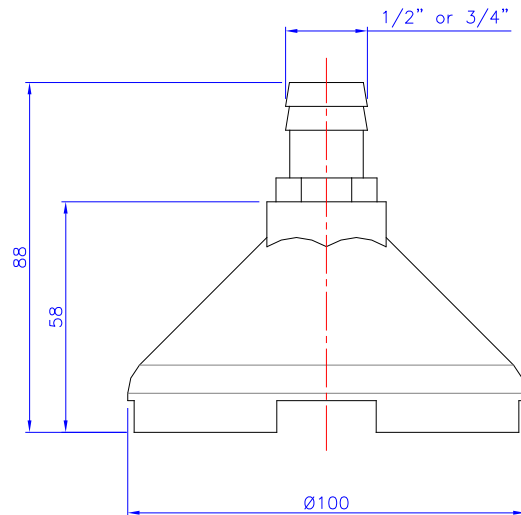

TUBULAR FILTER

Standard body in nylon. Mesh 600 μ m, available with threaded bushing, hose connection, Stainless Steel tube, or rubber hose.

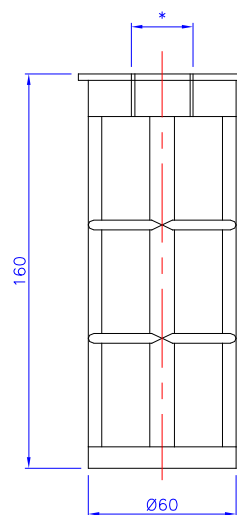

TANKS

STAINLESS STEEL TANK

Stainless Steel Tank with inspectionable lid. Cover with customizable holes. Available with or without wheels. Standard size: 40 / 65 / 100 liters. Others sizes upon request.

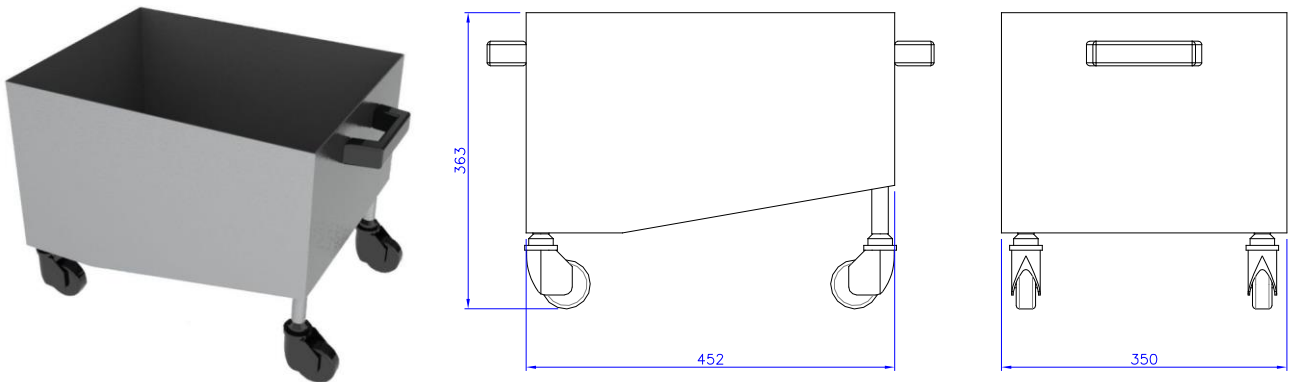

Dimensions for 40 liters size

TANK WITH INTERSTITIAL SPACE IN STAINLESS STEEL

Tank with Interstitial Space in Stainless Steel to easily control the temperature of the processed fluid. Inspectionable lid with customizable holes. Standard size: 55 liters. Others sizes upon request.

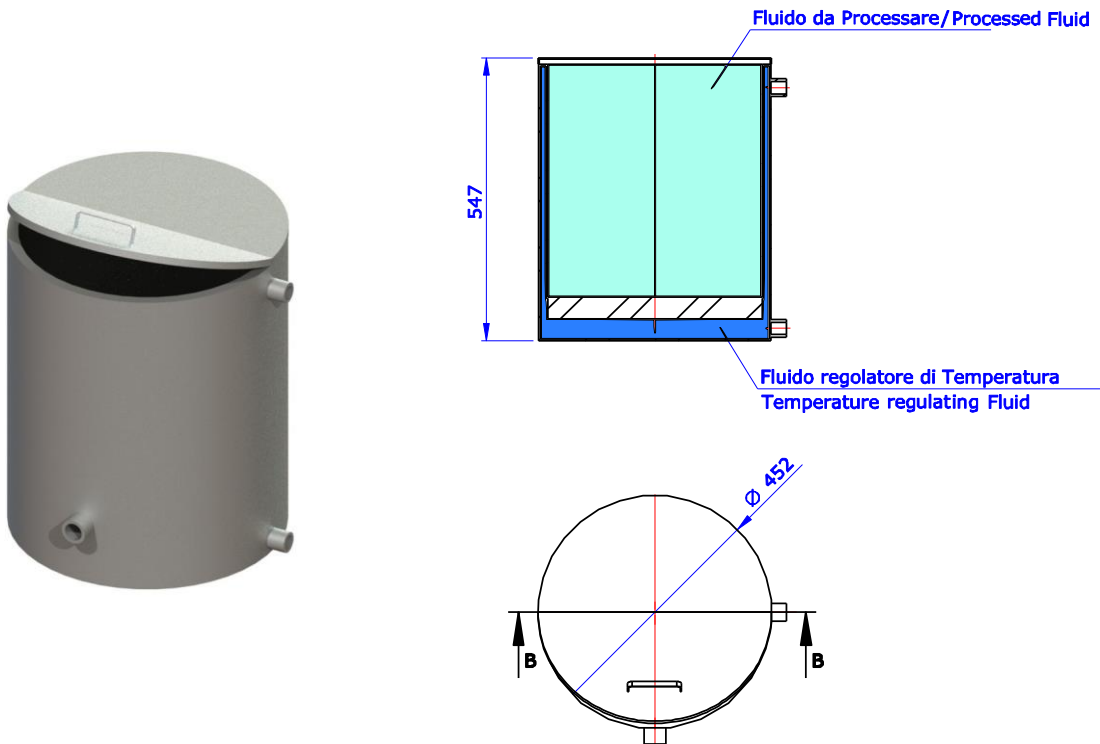

SETS

TANK / DIAPHRAGM PUMP SET

Pre-assembled. Customizable with every accessory.

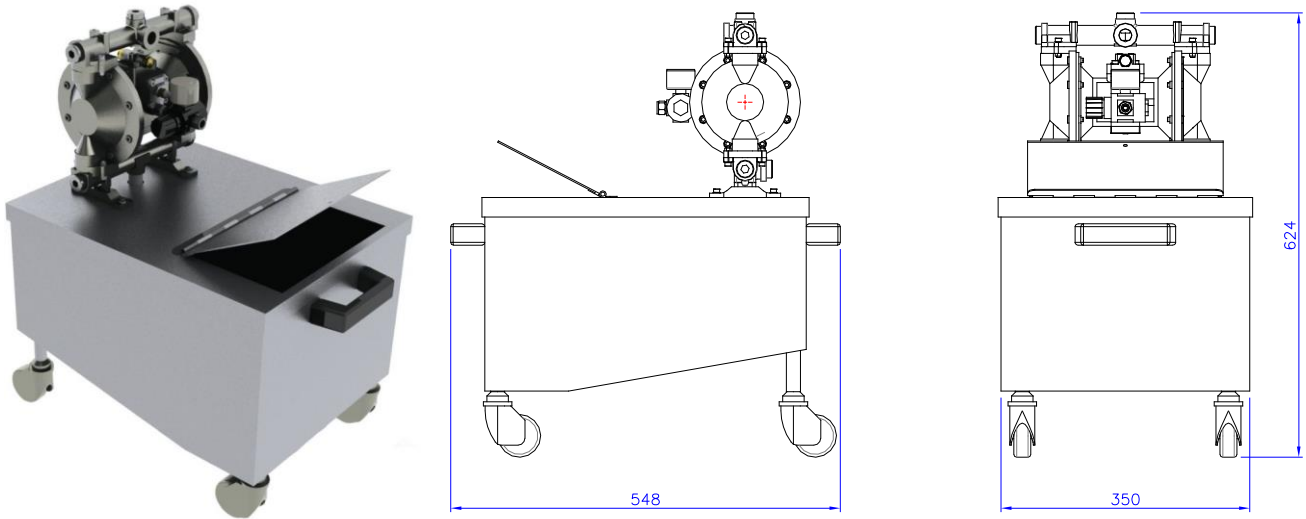

SET PUMP/BARREL COVER

Barrel Cover in Stainless Steel. Customizable suction height. with accessories.

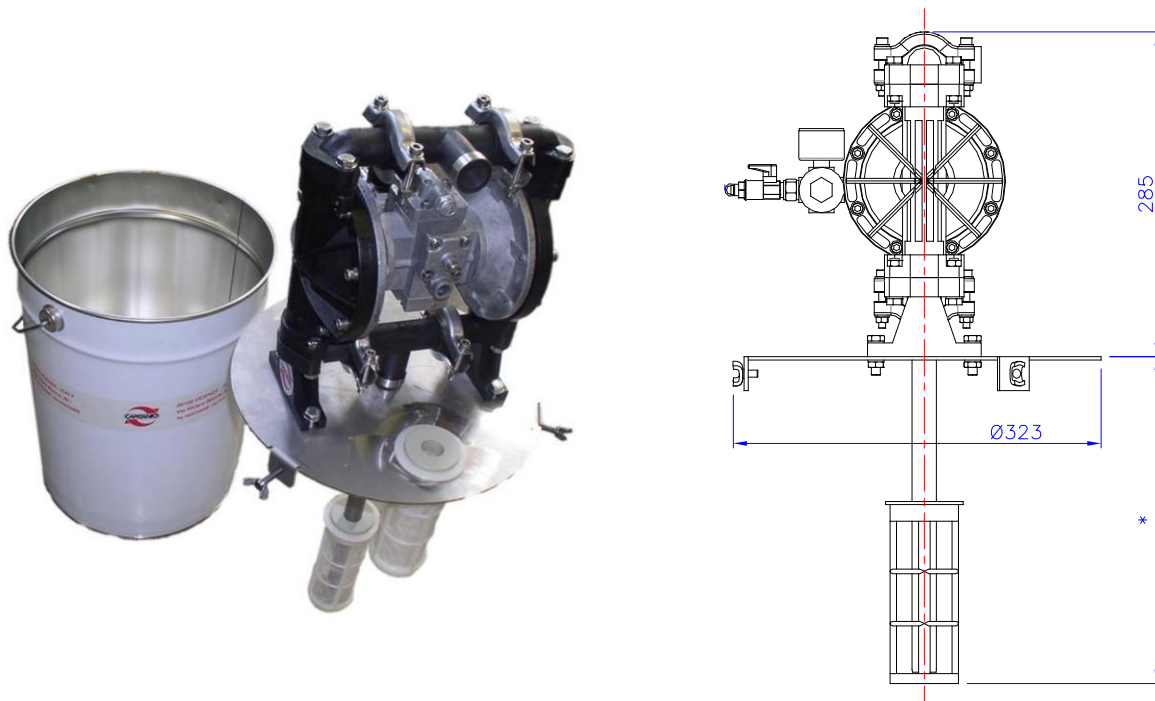

ADJUSTING KITS

ADJUSTING KITS FOR 200 LITERS BARRELS OR 1000 LITERS TANKS.

Customizable suction heights upon request.

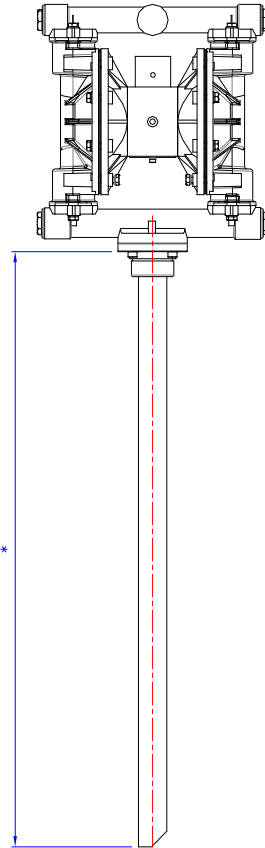

SUPPORTS

CART

Black varnished Steel Cart

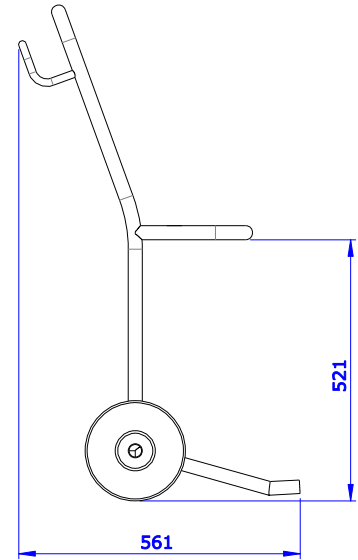
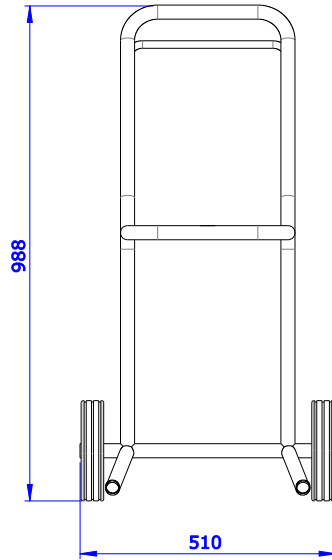

BRACKET FOR WALL MOUNTING

Diaphragm Pump Stainless Steel bracket for wall mounting



FAST COLOR

DESCRIPTION

Fast Color is a completed package specially designed for spray painting.

MAIN CHARACTERISTICS

- Capitania Airpumps diaphragm pump
- Stainless Steel Kart
- Spraying gun with interchangeable nozzle
- Inlet and Outlet filters
- Air Treatment kits for both pump and gun
- Selectable Fluid Transfer modality

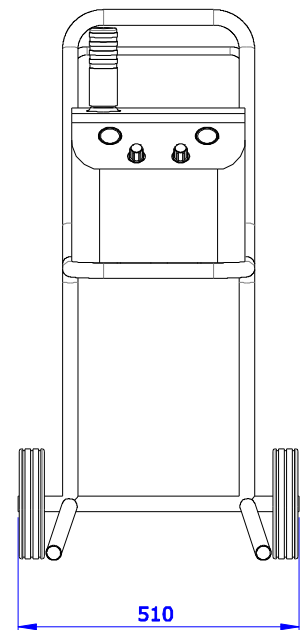
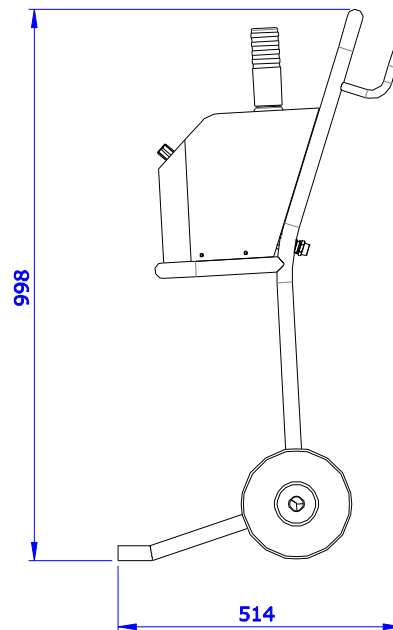

LIFTER

DESCRIPTION

Winch lifter, Stainless Steel frame. It facilitates pump handling, for example in barrel exchanges.

Weight: 50 Kg

Maximum lifting capacity: 180 Kg

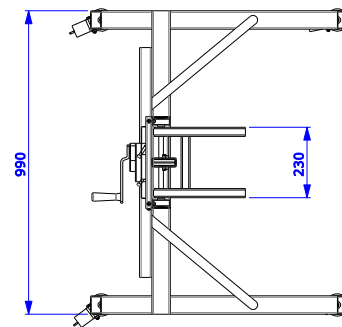
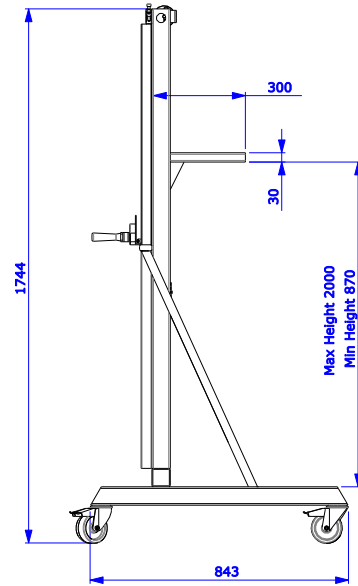







Capitano Airpumps s.r.l. – Via Brigata Mazzini 35/A 36016 – Thiene (VI)
Tel. +39 0445 185.65.65 – Fax. +39 0445 185.65.00
www.airpumps.it capitano@airpumps.it